



CE 1026

INSTALLATION, SERVICE AND MAINTENANCE INSTRUCTIONS



***Explosion-proof electric linear thrust
actuators ST 1-Ex***

TEST CERTIFICATE

EXPLOSION-PROOF ELECTRIC LINEAR THRUST ACTUATOR ST 1-Ex

Type number 411..... Power supplyVHz
Serial number Set switch-off thrust N
Production year Operating speed mm/min
Wiring diagram Operating stroke mm
Warranty period months Transmitter.....
Serial number of electric motor
Serial number of transmitter
Serial number of controller

Explosion-proof version: Ex II 2 G c Ex de IIB T6 Gb and Ex II 2 D Ex tb IIIC T85°C Db

Final report No.: FTZÚ 03 ATEX 0273X

Design and type tests are in accordance with the following standards:

- EN 60 079-0 – Electrical apparatus for explosive gas atmospheres – Part 0: **General requirement**
- EN 60 079-1 – Electrical apparatus for explosive gas atmospheres – Part 1: **Flameproof enclosures “d”**
- EN 60 079-7 – Explosive atmospheres Part 7: **Equipment protection by increased safety “e”**
- EN/IEC 60 079-31: Explosive atmospheres – Part 31: **Equipment dust ignition protection by enclosure „t”**.

Tests made in accordance with TP 74 0905 00

Tests made by

Date Signature and stamp

COMPLETENESS CERTIFICATE

Used valve

Assembled by: Firm

Name

Warranty period months

Date Signature and stamp

INSTALLATION CERTIFICATE

Location

Installed by: Firm

Name

Warranty period months

Date Signature and stamp

Contents

1. General data	2
1.1 Purpose and applications	2
1.2 Safety instructions	2
1.3 Product influence to environment	2
1.4 Data specified on electric actuator	3
1.5 Terminology	4
1.6 Instructions for staff training	5
1.7 Warning for safety use	5
1.8 Warranty conditions	5
1.9 Under-guarantee and after-guarantee service	5
1.10 Operation conditions	6
1.10.2 Working environment	6
1.10.3 Power supply and duty cycle	7
1.11 Packing, transport, storing and unpacking	7
1.12 Appreciation of the product and packing	8
2. Description, function and specifications	8
2.1 Description and function	8
2.2 Basic specifications	9
3. Installation and dismantling of actuator	12
3.1 Mechanical connection	12
3.1.1 Mechanical connection with connection dimensions according to ISO (DIN) Standards	12
3.1.2 Mechanical connection for pillar versions with flanges of A, B, C and D types	13
3.2 Electric connection and checking of function	13
3.3 Dismantling	15
4. Adjusting of actuator	15
4.1 Gear unit adjustment	16
4.2 Adjustment of position-indicating unit (Fig.4)	16
4.3 Adjustment of resistant transmitter (Fig. 5)	16
4.4 Adjustment of the Electronic Position Transmitter (EPV) - the Resistive Transmitter (Potentiometer) with the Converter PTK 1	17
4.4.1 EPV – the 2-wire version (Fig. 6)	17
4.4.2 EPV – 3-wire version (Fig. 7)	17
4.5 Adjustment of the Capacitive Transmitter CPT1/A (Fig.8)	18
4.6 Adjustment of position controller (Fig. 9)	19
4.6.1 Setting of controller	20
4.6.2 Watching operation and error states	21
5. Service, maintenance and troubleshooting	21
5.1 Service	21
5.2 Maintenance - extent and periodicity	21
5.3 Maintenance to assure inexplosiveness	22
5.4 Troubleshooting	22
6. Accessories	23
7. Enclosures	23
7.1 Wiring diagrams	23
7.2 Dimensional drawings	28
7.3 List of contractual after-sales service centres	29

The Installation, Service and Maintenance Instructions are drawn up according to requirements of EC Executive Nr. 89/392/EEC "Uniform requirements for machines and devices from the point of view of safety and health care", to save life and health of users and to avoid material damages and exposure environment to danger.

1. General data

1.1 Purpose and applications

Explosion - proof electric linear actuators (hereinafter EA) types **ST 1-Ex** resp. EA with controller types are high-powered electric-mechanical products, designed for direct installations onto controlled devices (regulating bodies -valves, etc.). EA of **ST 1-Ex** types are provided for remote control of closing bodies, and EA with controller for automotive control of regulating bodies in both directions of their movement. They can be equipped with means of measuring and control of technological processes where an unified analogue direct current or voltage signal is an information bearer on their input and/or output. They can be used in heating, energy, gas, air-conditioning and other technological systems, which they are suitable for, regarding their features. They are connected with controlled devices with a flange according to, EN 15714-2 or using pillars and flanges.



1. **Do not count with tight closing performed by control signals of EA ST 1-Ex with controller.**
2. **It is forbidden to use EA as a lifting mechanism!**
3. **Switching of actuator by a semiconductor switches have to be consulted with producer.**

1.2 Safety instructions

Product characteristics from risk point of view

EA type ST 1-Ex is based on characteristics stated in part „Operating conditions“ and from the risk point of view the reserved technical device *with high risk*, while it is electric device of A group (see Regulation of MPSvR SR no. 508/2009 Statute, §2 and Attachment no. I, III. part, section A – valid for territory of SR).

EA are according to EN 61010-1:2010 dedicated to installation category (overload category) II.

In order to demonstrate the compliance with the requirements of the European Council directive on machinery 2006/42/EC, European Parliament and Council Directive **2014/34/EÚ** on equipment and protective systems intended for use in potentially explosive environment (designated as Directive ATEX 100a), directive of the Council 2014/35/EU on LVD and Council Directive 2014/30/EU on EMC, the electric actuators are subject to certification by authorized certification facilities.

The product meets the essential safety requirements according to EN 60204-1 and is in compliance with EN 55011/A1 within valid edition.

1.3 Product influence to environment

Electromagnetic compatibility (EMC): the product complies with the requirements of the Directive 2014/30/EU of the European Parliament and of the Council on the approximation of the laws the Member States relating to the electromagnetic compatibility and with the requirements of standards as well EN/IEC 61000-6-4+A1, EN/IEC 61000-6-2, EN/IEC 61000-3-2 and EN/IEC 61000-3-3 within valid edition.

Vibrations caused by the product: product influence is negligible.

Noise produced by the product: The maximum allowable noise level (A) of the product measured in a place of operation is 80dB (A).

Electric actuators are made in explosion-proof version $\text{Ex} \text{ II } 2 \text{ Gc Ex de II B T6 Gb}$ and $\text{Ex} \text{ II } 2 \text{ D Ex tb}$ IIIC T85°C Db, pursuant to:

IEC/EN 60079-0: Explosive atmospheres – Part 0 : Equipment general requirements – General requirements

IEC/EN 60079-1: Explosive atmospheres – Part 1 : Equipment protection by flameproof enclosures "d"

IEC/EN 60079-7: Explosive atmospheres - Part 7: Equipment protection by increased safety "e".

IEC/EN 60079-31: Explosive atmospheres – Part 31: Equipment dust ignition protection by enclosure „t“, within valid edition.

Electric parts EA are proposed:

- as devices of the group **II** for others threatened areas (excluding mines)
- of the category **2** with demanding requirements for safety
- for use max. in zone **1**
- for atmospheres **G** (gases, vapors or mists) or **D** (combustible conductive dusts)
- topressure range from 0.8 to 1.1 bar.

Design version is :

- flameproof enclosures “**d**”, increased safety “**e**” or level dust ignition protection by enclosure “**tb**”
- with explosion protection group **IIB** or **IIIC**
- and temperature class **T6** (max. permissible surface temperature +85°C).

Zones for installation of explosion-proof electric actuators and conditions for equipment installation are defined in the following standards:

- IEC/ EN 60079-10: Electrical apparatus for explosive gas atmospheres
Part 10: Classification of hazardous areas
- IEC/ EN 60079-14: Electrical apparatus for explosive gas atmospheres
Part 14: Electrical installations in hazardous areas

Non-electric parts of electric actuators are designed, engineered, manufactured, tested and identified in compliance with the requirements for safety of machinery according to the following standards:

- EN 1127-1: Explosive atmospheres – Explosion prevention and protection
Part 1: Basic concepts and methodology
- EN 13463-1: Non – electrical equipment potentially explosive atmospheres
Part 1 : Basic method and requirements
- EN 13463-5: Non – electrical equipment potentially explosive atmospheres
Part 5: Protection by constructional safety “c”

Equipment identification consists of the following characters:

Ex - electric equipment complies with standard IEC/EN 60 079-0. and related standards for the corresponding types of explosion protection.

d - identification of the explosion protection type - "flameproof enclosure" according to IEC/EN 60 079-1.

e - identification of the explosion **protection type** – „increased safety" according to EN/IEC 60 079-7.

tb - identification of dust ignition protection by enclosure „t" according to IEC/EN 60 079-31.

II or III - identification of the class of non-explosive electric device according to the standard IEC/EN 60 079-0.

B or C - identification of the **sub-class II** or **III** of non-explosive electric devices according to the standard IEC/EN 60 079-0.

T6 or T85°C - identification of the **temperature class** of non-explosive electric device class II or III according to the IEC/EN 60 079-0.

Gb - (EPL Gb) - identification of the equipment designated for explosive gaseous atmospheres, with "high" level of protection, which is not a source of initiation in standard operation or in case of expected failures.

Db - (EPL Db) - identification of the equipment designated for explosive dust atmospheres, having a “high” level of protection, which is not a source o ignition in normal operation or during expected malfunctions.

1.4 Data specified on electric actuator

Nameplate for

Warning plate:

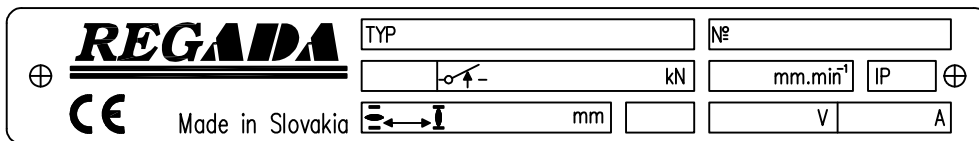

Nameplate contains the basic data concerning identification, performance and electricity: indication of producer, type, serial number, max. load thrust and switching-off thrust, operating speed, protection code, operating stroke, supply voltage and current.

Warning label:

- with identification of the waiting time and requirements for strength of screws.

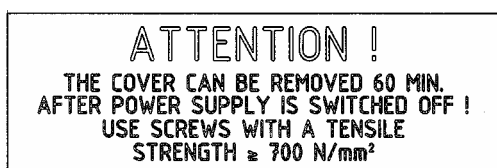



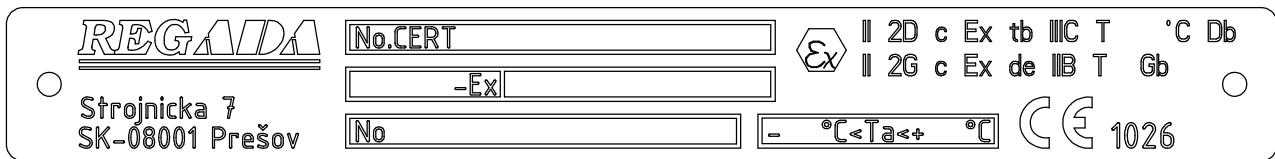



Non-explosive label: identifying the manufacturer, certificate number, type identification, version identification, serial number and version for ambient temperature -25°C to +55°C or -50°C to +40°C.

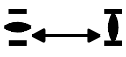

Graphic symbols on electric actuator

The graphic symbols used on electric actuator substitute the text messages. Some of them are in accordance with EN ISO 7010, ISO 7000 and IEC 60417.

	Dangerous voltage	(EN ISO 7010-W012)
	CAUTION! ¹⁾	(EN ISO 7010-W001)
	Stroke of the electric linear actuator	
	Switching-off thrust	
	Manual control	(0096 ISO 7000)
	Protection terminal	(5019 IEC 60417)

1.5 Terminology

Potentially explosive environment - an environment where explosive atmosphere can occur.

Explosive gas atmosphere - a mixture of flammable substances (in form of gases, vapors or mist) with air under atmospheric conditions, which upon initiation enables the propagation of the combustion in unconsumed mixture.

Maximum surface temperature - maximum temperature occurring during operation in most adverse conditions (but within accepted tolerance limits) at any part of the surface of the electric device, that could result in ignition of the surrounding atmosphere.

Enclosure - all walls, doors, covers, cable glands, shafts, rods, draw bars, etc., that contribute to the level of protection against explosion or to the level of protection (IP) of the electric device.

Flameproof enclosure "d" - type of protection wherein the parts capable of igniting an explosive atmosphere are located within the enclosure, in case of explosion of an explosive mixture within the enclosure, such enclosure will withstand the pressure of the explosion and prevent the propagation of explosion to the surrounding atmosphere.

Increased safety "e" - type of protection applied to electrical apparatus in which additional measures are applied so as to give increased security against the possibility of excessive temperatures and of the occurrence of arcs and sparks in normal service or under specified abnormal conditions.

Dust ignition protection by enclosure "t" – type of protection for explosive dust atmospheres where electrical equipment is provided with an enclosure providing dust ingress protection and a means to limit surface temperatures.

Combustible dust - finely divided solid particles, 500 µm or less in nominal size, which may be suspended in air, may settle out of the atmosphere under their own weight, may burn or glow in air, and may form explosive mixtures with air at atmospheric pressure and normal temperatures¹⁾.

Conductive dust - combustible dust with electrical resistivity equal to or less than 10³ Ω · m.

Combustible flyings - solid particles, including fibres, greater than 500 µm in nominal size which may be suspended in air and could settle out of the atmosphere under their own weight.

¹⁾ See. chapter 3.2

1.6 Instructions for stuff training

Requirements for specialized skills of persons performing assembly, operation and maintenance



Electric connection can be performed only by an acquainted person, i.e. an electrical engineer with professional education of electrical engineering at an apprentice school or a technical school (secondary, complete secondary or university education) and whose qualification was verified by an educational facility authorised to verify professional qualification.



Service can be performed only by workers professionally qualified and trained by the producer or contracted service centre!

1.7 Warning for safety use

1. Products are assigned for operation in environments consist from gases, steams and vapours or with flammable conductive dusts , temperature range from -25°C up to $+55^{\circ}\text{C}$; and special version for ultra low temperatures from -50°C up to $+40^{\circ}\text{C}$, with pressure range from 0.8 to 1.1 bar.

It matters about following products are designated for enviroment:

- group **II**
 - the category **2**
 - for type of the atmospheres **G** or **D**
 - subgroup **B**
 - temperature class **T6**.
2. Products are designed according to standards for electrical and non-electrical devices assigned for areas with danger of explosion:
 - for electric parts: IEC/EN 60079-0, IEC/EN 60079-1 and IEC/ EN 60079-7 and IEC/EN 60079-31.
 - for non-electric parts: EN 1127-1 , EN 13463-1 and EN 13463-5.
 3. The maximum surface temperature of the actuator for given group **T6** is not allowed to exceed $+85^{\circ}\text{C}$.
 4. If the actuator is placed on device which regulate medium with higher temperature than $+55^{\circ}\text{C}$, protect the actuator by additional construction in order to maintain ambient temperature max. $+55^{\circ}\text{C}$ and also to stop temperature transmitting through junction component!
 5. Cable glands blinds are assigned only for transport and storage period, i.e. for period till the actuator is builded into operation with danger of explosion, than blinds must be replace by connecting cable.
 6. If any of the cable glands are not used to install a cable, it must be replaced with certified Ex plug of the approved type, secured with Loctite 243 adhesive.
 7. Temperature on entry cables is max. 90°C .
 8. CAUTION !: The cover can be removed 60 minutes after power supply is switched off! Use screws with a tensile strength of $\geq 700 \text{ N/mm}^2$.
 9. **WARNING – POTENTIAL ELECTROSTATIC CHARGING HAZARD.**

During operation of EA it must be prevented any process with intensive formation of electrostatic charge stronger than manual friction of his surface.

Product protection

EA does not have own short-circuit protection, therefore there must be included suitable protective device into the supply power (circuit breaker, or fuse), which serves at the same time as main switch.

Type of equipment from a connection point of view: The equipment is designed for permanent connection.

1.8 Warranty conditions

The supplier is responsible for completeness of the delivery and guarantees these specifications of the product which are stated in the Contract.

The supplier is not responsible for any deterioration of parameters caused by the customer during storage, unauthorised installation or improper operation.

1.9 Under-guarantee and after-guarantee service

Our customers are provided with professional service of our firm in installation, operation, service, maintenance, revision and help in troubleshooting for all our products.

Trained professionals wait for you also in our contracted service centres.

Under-guarantee service is performed by the service department of the production plant, or by a contracted service centre according to a written claim.

In case of occurring of any fault please let us know it and state:

- type code
- serial number
- ambient parameters (temperature, humidity...)
- duty cycle including frequency of switching
- type of switching-off (position or thrust)
- set switching-off thrust
- type of fault - description of claimed fault
- it is recommended to place also Installation certificate.

It is recommended to have **after-guarantee service** performed by the service department of the production plant, or by a contracted service centre.

1.10 Operation conditions

1.10.1 Product location and operation position

EA can be installed and operated at sheltered areas of industrial plants without temperature and humidity regulation, protected against climate effects (e.g. direct sunshine), also **at areas with explosion danger of inflammable gases and steam**, specified as **zone 2** and **1**, i.e. **at areas where is possibility of originating explosive vapour atmosphere within standard operation** (according to EN/IEC 60079-10).

Installation and operation of EA is possible in **any position**. Vertical position of output part axis and with the control part above the valve is usual.

Warning:



Actuator installed on the open place must be protected against a direct climate effects by shelter. Actuator installed in the place with relative humidity over 80% and on the open place under shelter have to have permanently connected space heater without thermal switch.

1.10.2 Working environment

According to standard IEC 60 721-2-1 within valid edition.:

EA have to resist external effects and operate reliably:

- in climatic conditions for the group / type of climate:
 - version „**standard**“ - for climate group **Restricted (R)** + Warm temperature (WT), Warm Dry (WDr), Mild Warm Dry (MWDr) and Extremely Warm Dry (EWDr) with corrosion resistance C3 resp. C4 (EN ISO 12944-2), with temperatures -25°C to +55°C
 - version „**universal**“ - for climate group **General (G)** / Cold (C), Cool Temperature (CT), Warm Temperature (WT), Warm Dry (WDr), Mild Warm Dry (MWDr), Warm Damp (WDa) and Warm Damp Equable (WDaE) with corrosion resistance C3 (EN ISO 12944-2), with temperatures -50°C to +40°C

CATEGORY OF LOCATION

- executions "**Standard**" and "**Universal**" are intended for location under the shelter (category 2).

ATMOSPHERE TYPE

- executions "**Standard**" and "**Universal**" are intended for location in atmosphere type II industrial.

(In accordance with IEC 60 364-1, IEC 60 364-5-51 and IEC 60 364-5-55 within valid edition)

EA have to resist external influences and work for a certainty:

In conditions of external environment marked as:

- warm mild to very hot dry with temperatures -25°C to +55°CAA 7*
- cold, warm mild to hot dry with temperatures -50°C to +40°CAA 8*
- with relative humidity 10÷100%, including condensation with maximum content 0,028kg of water in 1kg of dry air at temperature 27°C, with temperatures -25°C to +55°C.....AB 7*
- with relative humidity 15÷100%, including condensation with maximum content 0,036kg of water in 1kg of dry air at temperature 33°C with possibility of aerial collisions activity, with temperatures -50°C to +40°AB 8*
- with elevation up to 2000 m, with barometric pressure range from 86 kPa up to 108 kPa AC 1*
- with shallow dive – (product in protection IP x 7) AD 7*

- with strong dustiness – with a possibility of influences of inflammable, non-conducted and non-explosive dust; the middle layer of dust; the dust drop more than 350 but not more than 1000 mg/m² per day (products with protection enclosure of IP 6x)AE 6*
- with occasional or casual appearance of corroding and polluting substances (occasional or casual expose to corroding or pollute chemical substances during producing or using of these substances); at places where is handled with small quantity of chemical products and these can accidentally get in contact with an electric deviceAF 3*
- with a possibility of influences of mechanical stress:
 - medium sinusoid vibrations with frequency in range from 10 up to 150 Hz, with shift amplitude of 0,15 mm for $f < f_p$ and acceleration amplitude 9.8 m/s^2 for $f > f_p$ (transition frequency f_p is from 57 up to 62Hz)AH 2*
 - medium impacts, shocks and vibrationsAG 2*
- with serious danger of plants and mould growingAK 2*
- with serious danger of animal occurrence (insects, birds, small animals)AL 2*
- with detrimental influence of radiation:
 - of stray current with intensity of magnetic field (direct or alternate, of mains frequency) up to $400 \text{ A} \cdot \text{m}^{-1}$ AM2*
 - of sun radiation with intensity > 500 and $\leq 700 \text{ W/m}^2$ AN 2*
- with effects of medium seismic activity with acceleration $> 300 \text{ Gal}$ $\leq 600 \text{ Gal}$ AP 3*
- with indirect endanger by stormAQ 2*
- with quick air movement and strong windAR 3 , AS 3*
- stand on a conductive bottom)BC 3*
- with a danger of inflammable gases and vapours explosion - for Ex of versionBE 3N2*
- fire risksBE 2*

* Marking in accordance with IEC 60364-1, IEC 60 364-5-51 and IEC 60 364-5-55 within valid edition

1.10.3 Power supply and duty cycle

Power supply:

electric motor.....	230 V AC $\pm 10\%$, 3x400 V AC $\pm 10\%$, resp. 24 V AC/DC $\pm 10\%$
control.....	230 V AC $\pm 10\%$, resp.24 V AC $\pm 10\%$
potentiometer transmitter	max. $\sqrt{P \times R}$ V DC/AC
electronic positional transmitter (EPV) without power supply	15 up to 30 V DC, or 24 V DC
capacitive transmitter without power supply	18 up to 28 V DC
power supply frequency	50 Hz, or 60* Hz $\pm 2\%$

* Note: At frequency of 60 Hz closing time is reduced by 1.2 times t .

Duty cycle - according to EN/IEC 60034-1, 8:

EA ST 1-Ex are designed for **remote control**:

- short-time operation S2-10 min
- intermitted operation S4-25%, max. 90 cycles per hour

EA ST 1-Ex with controller are designed for **automotive regulation**:

- intermitted operation S4-25%, 90 up to 1200 cycles per hour

Note:

1. Duty cycle consist of load type, load factor and switching rate.
2. EA ST 1-Ex is possible connect with an external controller and use this EA as controlled EA, for this EA stands duty cycle and power parameters as for type ST 1-Ex with built-in controller. For EA with controller we do not suggest operating speed 63 and 80 mm per min.

1.11 Packing, transport, storing and unpacking

Plochy bez povrchovej úpravy sú pred zabalením ošetrované konzervačným prípravkom MOGUL LV 2-3. Preservation is not necessary if the following storage conditions are complied with:

- Storage temperature: -10 to +50 °C
- Relative air humidity max.80 %
- Electric actuators and their accessories must be stored in dry, well ventilated covered spaces, protected against impurities, dust, soil humidity (by placement to racks, or on palletes), chemicals and foreign interventions
- There shall be no corrosive gases present in the storage areas

The of **EA ST 1-Ex** are delivered in solid packages guaranteeing resistance in accordance with EN/IEC 60 654.

Package is a box. Products in boxes is possible to load on the pallets (pallet is returnable). On the outer side of the package is stated:

- manufacturer label,
- name and type of product,
- number of pieces,
- other data – notices and stickers.

The forwarder is obliged to secure packed products, loaded on transportation means, against self-motion; if open transportation means are used, to secure their protection against atmospheric precipitations and splashing water. Displacement and securing of products in transportation means must provide their stable position, exclude the possibility of their inter-collision and their collision with the vehicle walls.

Transportation can be executed by heatless and non hermetic spaces of transportation vehicles with influences within the range:

- temperature: -25°C up to +70°C (a strange version –45 ° C up to +45 ° C)
- humidity: 5 up to 100 %, with max. water content 0.028 kg/kg of dry air
- barometric pressure 86 up to 108 kPa

After receiving EA check whether during transport or storage the actuator was not damaged. Compare also whether the parameters on their nameplates are in accordance with accompanying documentation or the Contract. If any discrepancy or fault occur inform immediately your supplier.

If the actuators and accessories are not immediately installed, they have to be stored in dry, well-ventilated sheltered rooms, protected against dirt, dust, soil humidity (with placing onto shelves or onto pallets), chemical impacts and encroachment, at ambient temperature from -10°C up to +50 °C and relative humidity max. 80 %.

It is not allowed to store EA in the open air or in areas not protected against direct impact of climate!

If any scratch on the surface finishing occurs remove it immediately - you protect this way actuators against damaging with corrosion.

1.12 Appreciation of the product and packing

The product and its package are made of recycling materials. Do not throw the single parts of the package and of the product after their life but sort them according to instructions in corresponding executives or regulations of environment protection, and allow their recycling.

The product and its packing are not a source of any environment pollution or contamination and do not contain any dangerous waste.

2. Description, function and specifications

2.1 Description and function

The explosion-proof **ST 1-Ex, ST 1-Ex with controller** electric actuators consist of three parts differing in their function. The gear part is placed in the bottom and covered with a board (2)(Fig.3) where the control part is located. After removing of the upper cover only the control part is visible. The terminal board (6))(Fig.3) is located separately, in the terminal board case with bushings (12))(Fig.3) connected with the control part using the 12-core bushing (16))(Fig.3). The actuator linear movement and connection to the valve is provided by the gear part fastened on the gear part output.

The power output of the reversible asynchronous motor is led through the two-stage spur gearing with a brake, the planet gearing with Wolform tear teeth to the motion screw where the output screw is moving along. For various speed values various numbers of gear wheels in the input gearing are used. In the planet gear the movement from the worm gearing used for the manual control (11))(Fig.3) the movement needed for thrust switching (4))(Fig.3) is derived. The switching thrust is continuously adjustable.

In the countershaft the pinions are made of metal, wheels are of plastics, what results in reduced actuator noisiness. The splined shaft connected with the control central wheel leads from the crown gear. The central wheel is placed in the board bearing removable after loosening the fixing screws.

The board is compact and consists of:

- the position-indication unit,
- the gear unit,
- the transmitter unit,
- the electric motor with a capacitor,
- the space heater with the thermal switch.

The position-indication and transmitter units are driven with the gear unit. The position-indication unit (3) (Fig. 3) consists of the cam system (24, 25, 26 and 27)(Fig.4). The cams are locked centrally with the nuts (23) while the cams themselves are adjustable using friction washers. The cam system allows adjusting of permanent indication from 0 up to 100% of the operation stroke. Remote position watching or control is provided by the

position transmitter (potentiometer) (5)(Fig.3). The enlarged part of the lower case is designed for the terminal board case. With removing of the terminal board case the composed terminal board (6) is visible.

Additional accessories:

Manual control: made up by a hand wheel with a worm gearing.
The **ST 1-Ex with controller** version is equipped with an **electronic controller**.

2.2 Basic specifications

Basic EA specifications:

switching-off thrust [N], operating speed [mm/min], operating stroke [mm], max. load thrust (valid for ST 1-Ex with controller) [N] and electric motor parameters are given in Table 1.

Table 1: Basic specifications

Type number	Operating speed ±10[%] ¹⁾	Operating stroke	Max. load thrust (ST 1-Ex with controller)	Switching-off thrust ±10 [%]	Weight	Electric motor ³⁾					
						Power supply nominal voltage	Nominal			Capacitor capacity	
							power	speed	current		
	[mm/min]	[mm]	[N]	[N]	[kg]	[V] ±10%	[W]	[1/min]	[A]	[µF/V]	
1	2	3	5	6	7	8	9	10	11	12	13
ST 1-Ex, type number 411	8	10; 12,5; 16; 20; 25; 32; 40; 50; 64; 80	7000	8000-10000	11,0 – 15,0	Single-phase	230	15	2750	0,18	2,2/400
	16										
	32										
	63 ²⁾										
	10										
	20										
	40										
	80 ²⁾										
	8		7000	8000-10000	11,0 – 15,0	Three-phase	3x400	15	2680	0,10	-
	16										
	32										
	63 ²⁾										
	10										
	20										
	40										
	80 ²⁾										
	8		7000	8000-10000	11,0 – 15,0	Single-phase/ direct current	24 AC/DC	20	2750	1,80	-
	16										
	32										
	63 ²⁾										
	10										
	20										
	40										
	80 ²⁾										

- 1) Anomaly of operating speed: -15% at temperatures under -10°C
± 10% at 230 V (or 3x400 V) AC
-50 up to +30% in dependence on load at 24 V AC/DC.
- 2) Valid for version without controller.
- 3) Switching elements for different type of load (also for EA) defines standard EN/IEC 60 947-4-1.

Additional technical data:

EA protection enclosure:IP 67 (EN/IEC 60529)

Mechanical ruggedness:

sinusoidal vibrations: with frequency in range 10 to 150 Hz,
with shift amplitude of 0,15 mm for $f < f_p$,
with acceleration amplitude of $19,6 \text{ m/s}^2$ for $f > f_p$,
(transition frequency $f_p = 57$ to 62 Hz)

drop resistance:300 drops with acceleration 2 m.s^{-2}

seismic resistance:amplitude of the shock off 6 on Richter scale

Self-locking: with mechanical brake

Electric motor protection: with thermal switch

EA braking: with mechanical brake

Output part backlash:..... < 0,5 mm at load of 5%-of maximum thrust

Switching-off

Voltage max. 250 V; 50/60 Hz; 2 A, or 250 V DC; 0,1 A

Hysteresis of position switches max. 3%

Switching-off thrust is adjusted to maximum value with tolerance $\pm 10\%$ if not agreed else.

Operation stroke is adjusted at producer according to specified value.

Space heater (E1)

Space heater - supply voltage: corresponding with motor supply voltage (max. 250 V AC)

Space heater power output: max. 10 W / 55 °C

Thermal switch of space heater (F2)

Supply voltage: corresponding with motor supply voltage (max. 250V AC)

Switching-off temperature:..... $+30^{\circ}\text{C} \pm 3\text{K}$

Switching-on temperature:..... $+20^{\circ}\text{C} \pm 4\text{K}$

Position transmitters

Resistive position transmitter

Resistance (single **B1**) 100; 2 000 Ω
 (double **B2**) 2x100 Ω , 2x2000 Ω

Operating life of transmitter $1 \cdot 10^6$ cycles

Load capacity 0,5 W do 40 °C, (0 W/125°C)

Maximum current of sliding contact max.35 mA

Maximum supply voltage..... $\sqrt{P \times R}$ V DC/AC

Potentiometer linearity error $\pm 2,5 [\%]^{1)}$

Potentiometer hysteresis max. 2,5 $[\%]^{1)}$

Potentiometer values at limit positions:

for **ST 1-Ex**: "O" (open)..... $\geq 93\%$, "Z" (closed)..... $\leq 5\%$

for **ST 1-Ex with controller**: "O" (open)..... $\geq 85\%$, "Z" (closed)..... $\leq 5\%$

Capacitive (B3): non-contact, life 10^8 cycles

2-wire connection with power supply or without power supply

The current signal **4 ÷ 20 mA** (DC) is acquired from the capacitive transmitter supplied from the internal or an external voltage supply source. The electronics of the transmitter is protected against eventual wrong polarity and current overloading. The entire transmitter is galvanic insulated so several transmitters can be connected to one external voltage source.

Power supply voltage (with power supply) 24 V DC

Power supply voltage (without power supply) 18 to 28 V DC

Ripple voltage max. 5%

Max power input 0,6 W

Load resistance 0 to 500 Ω

Load resistance can be single side grounded.

Influence of resistance on output current 0,02%/100 Ω

Influence of voltage on output current 0,02%/1V

Temperature dependency 0.5% / 10 °C

Electronic positional transmitter (EPV) - converter R/I (B3)

a) 2-wire version - without built-in power supply

Current signal 4 ÷ 20 mA (DC)

Power supply voltage 15 to 30 V DC

Load resistance max. $R_L = (U_n - 9V) / 0,02A$ [Ω]

..... (U_n - power supply voltage [V])

Output signal values at limit positions:

"O" 20 mA (clamps 81; 82)

"Z" 4 mA (clamps 81; 82)

Values tolerance of output signal of EPV

"Z" $\pm 0,2$ mA

"O" $\pm 0,1$ mA

b) 3-wire version - without built-in power supply, or with built-in power supply

Current signal 0 ÷ 20 mA (DC)

Current signal 4 ÷ 20 mA (DC)

Current signal 0 ÷ 5 mA (DC)

Power supply voltage (at version without built-in power supply) 24 V DC $\pm 1,5\%$

Load resistance max. 3 k Ω

Output signal values at limit positions:

"O" 20 mA, or 5 mA (clamps 81; 82)

"Z" 0 mA, or 4 mA (clamps 81; 82)

Values tolerance of output signal of EPV and capacitive transmitter

"Z" +0,2 mA

"O" $\pm 0,1$ mA

EPV and capacitive transmitter linearity error $\pm 1,5[\%]$ ¹⁾

EPV and capacitive transmitter hysteresis max. $1,5 [\%]$ ¹⁾

1) from rated value of transmitter referred to output values

Electronic position controller (N)

Controller software equipment:

A) Function and parameters

programmable **functions**:

- ..with functional buttons SW1, SW2 and LED diodes D1, D4 directly placed on controller
- ..with computer or terminal equipped with corresponding programme, using RS 232 interface.

programmable **parameters**:

- ..control signal
- ..response to SYS-TEST signal
- ..mirroring (ascending/descending characteristics)
- ..insensitiveness
- ..EA limit positions (only with computer and ZP2 programme)
- ..way of regulation

B) Operation states of controller

Error message from error memory: (using LED diodes and RS 232 and personal computer)

- ..control signal missing or faulty
- ..input value of current control signal under 3.5 mA
- ..existence of SYS-TEST signal
- ..activity of switches
- ..failure of feedback position transmitter

Statistic data: (using RS 232 and personal computer)

- ..number of controller operation hours
- ..frequency of relay switching in direction "opening"
- ..frequency of relay switching in direction "closing"

Supply voltage: terminal 61 (L1) -1(N) 230 V AC, $\pm 10\%$

Frequency: 50/60 Hz $\pm 2\%$

Input control signals - analogue: 0 - 20 mA

..... 4 - 20 mA

..... 0 - 10 V

(Actuator opens at rising of control signal.)

Controller linearity: 0.5 %

Controller insensitiveness: 1 - 10% (adjustable)

Feedback (position transmitter): resistive 100 up to 10,000 Ω
current 4 up to 20 mA

Power outputs: 2x relay 5A/380V

Digital outputs: 4x LED (supply, error, adjustment, "opening", "closing" - with two-colour LED)

Error status: control switch 24 V, 2W - POR

Reaction at error situation: transmitter error - error message LED

Control signal missing: error message LED

SYS mode: error message LED

Adjusters: communication connector

2x calibrating and adjusting button

Manual control: with hand wheel; rotating clockwise (counterclockwise) EA output part is moving in direction "O" - open ("Z" - closed)

Mechanical connection: Basic and connecting dimensions are given in dimensional drawings.

Electric connection

with terminal board (X): - max. 12 terminals – connecting cable size from 0,5 to 2,5 mm²
 - 2 cable bushings – cable diameter from 9 to 13 mm

with protection terminal: - external and internal, mutually connected and marked with protection earthing mark.

Electric connection - according to **wiring diagrams**.

3. Installation and dismantling of actuator



Abide by safety measures!

Note:

Check again if placement of EA reply to chapter "Operation conditions". In case that operation conditions are different from recommended, consultation with producer is needed.

Before starting of mounting the EA onto the valve:

- Check again whether the EA was not damaged during storing.
- Check whether the adjusted operation stroke and connecting dimensions of the actuator (see the nameplate) are in compliance with the valve parameters.
- In case of inconsonance, perform adjusting according to the part "Adjustment".

3.1 Mechanical connection

EA is by the producer adjusted to parameters according to the nameplate, with connecting dimensions according to the corresponding dimensional drawing and put it to a mid-position.

Before installation put the hand wheel on.

3.1.1 Mechanical connection with connection dimensions according to ISO (DIN) Standards

- Properly defat contact surfaces of the EA connecting flange and the valve.
- Check the nameplates to assure that actuator and valve strokes are the same.
- Set the actuator (A) and the valve (B) to the position "closed".
- Put the actuator (A) onto the valve (B) to have the actuator shaft (3) leant onto the valve coupling (8).
- Turn the valve output shaft (5) to connect the stem with the valve output shaft having the actuator flange (2) sitting on the valve flange (7).
- Tighten the screws (4) with the cross system to connect the actuator flange (2) with the valve flange (7).
- Check connection dimensions in accordance with Fig. 1.
- Turn the valve output shaft (5) by one revolution and lock it with the nut (6) (to create pre-stressing against the valve seat).

A ... electric actuator

- 1 ... hand wheel
- 2 ... actuator flange
- 3 ... shaft
- 4 ... screw

B ... valve

- 5 ... valve output shaft
- 6 ... locking nut
- 7 ... valve flange
- 8 ... valve coupling

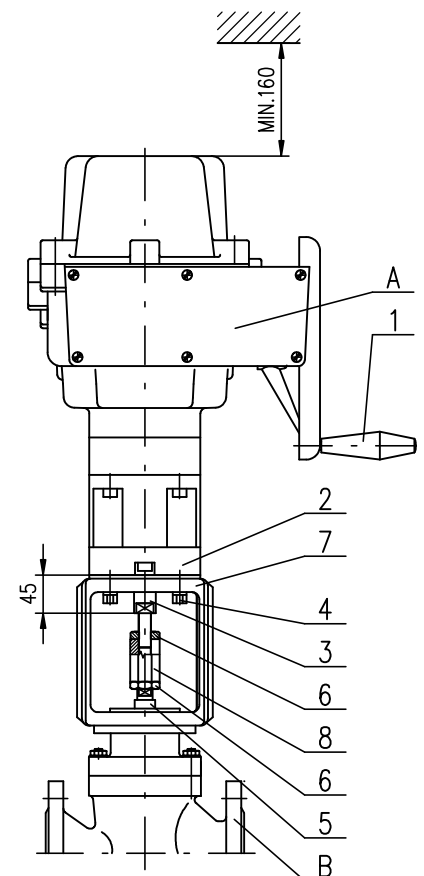

Fig. 1

3.1.2 Mechanical connection for pillar versions with flanges of A, B, C and D types

- Set the actuator (A) and the valve (B) to the position "closed".
- Loosen and unscrew two screws (5) on the actuator shaft (3) and disconnect the coupling clamping parts (8)
- Screw the coupling nut (9) onto the valve output shaft (6) (max. 28mm) to have an allowance between the coupling nut (9) and the actuator shaft (3) after the actuator is sat on.
- Place the actuator (A) onto the valve (B) and fix the actuator slightly with the screws (4a), or with the central nut (4) (according to shape of connecting flange of EA) in the way you be able to move it.
- By turning hand wheel (1) move end shaft EA (3) toward thread coupling (8) screwed onto valve output shaft (6) (or unscrew thread coupling)
- Put the clamping parts of the thread coupling (8) on, and tighten the both coupling screws (5) to have the coupling nut able to rotate
- Tighten the screws (4a), or central nut (4) with the cross system to fasten the actuator (2) and valve (7) flanges.
- Check the connection diameters in accordance with the Fig. 2.
- Unscrew the coupling nut (9) by one more revolution (to create the pre-stress against the valve seat), and tighten the coupling screws (5) firmly

Notes:

1. Minimum mechanical ruggedness of screws is 8G.
2. If adjustment of the position-signalling unit or the transmitter in the production plant do not correspond with the EA connected this way, adjust the units.

- In the end of mechanical connection check correctness of the connection with the valve with rotating the hand wheel.

A electric actuator

- 1 hand wheel
- 2 actuator flange
- 3 shaft
- 4 central nut
- 4a screw
- 5 screw

B ... valve

- 6 valve output shaft
- 7 valve flange
- 8 coupling

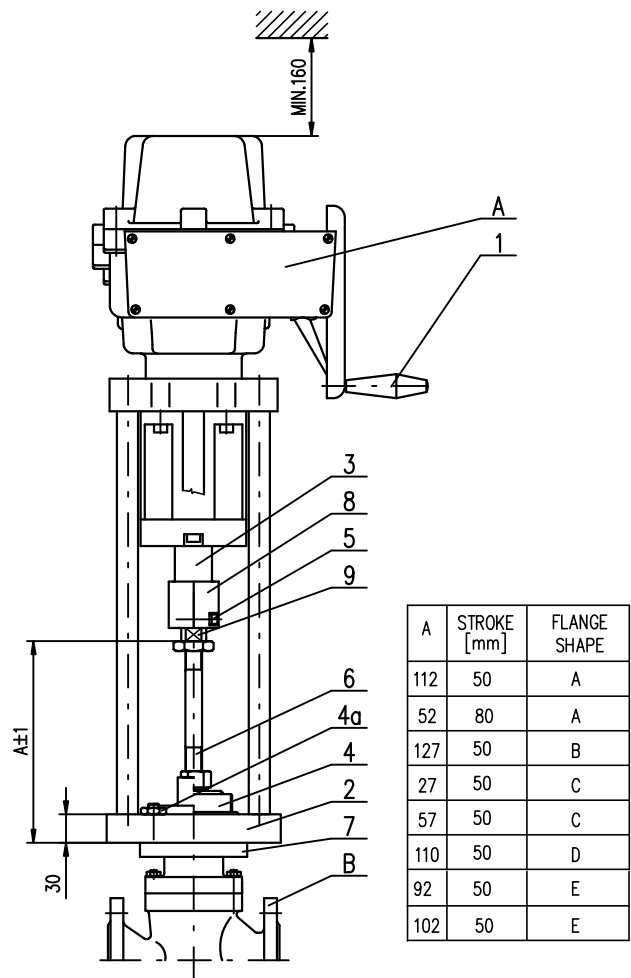

Fig.2

3.2 Electric connection and checking of function

Follow up with connecting the EA with mains or master system.



1. Follow instructions in the part "Requirements for professional qualification"!
2. While laying electrical line abide by the instructions for heavy current installations. Power supply cables must be of the type approved. Minimum thermal resistance of power supply cables and wires must be +90°C.
3. Cables to terminal boards or connectors lead through screw bushings.
4. Before initiation ES into operation internal and external protection terminals are needed to be connected.

5. Feeding cables are to be fixed to the solid construction at most 150 mm from the bushings.

Connecting with the master system:

The EA can be controlled with:

- a built-in position controller
- an external position controller



1. If the EA is controlled with an external controller using unified signal from a two-wire transmitter (capacitive or resistive with a converter in two-wire connection), it is needed to arrange connecting of the two-wire transmitter loop to electrical earth of the successive external controller!
2. Connection can be performed only in one point, in any part of loop out of the EA.
3. Electronics of the two-wire transmitters is galvanically insulated that is why it can serve as an external source for supplying of several transmitters (their number depends on current which the source can supply).
4. Do not connect and disconnect live connectors!

Connecting to terminal board

- Check whether the type of current, supply voltage and frequency correspond with data on the nameplate of electric motor.
- Remove the upper cover.
- In case of the single-phase version the phase I1 and the lead N connect to the corresponding terminals. In case of the three-phase version connect the phase cables L1, L2 and L3 to U, V, W (terminals 2, 3, 4), the protection cables to the marked places of internal and external protection terminals.
- Connect the control cables according to the wiring diagram placed into the internal side of the cover.
- Put the cover on and tighten it uniformly crosswisely.
- Tighten the cable bushings firmly to assure the protection enclosure rate.

Notes:

1. The EA are delivered with bushings, which in case of tight putting on the leads assure protection enclosure up to IP 67. For required protection enclosure it is needed to use rings according to the actual cable diameter.
2. While fixing the cable it is needed to count with allowed bend radius to avoid damaging or deformation of the sealing element of the bushing. The leads are to be fixed with the solid construction at most 150 mm from the bushings.
3. It is recommended to use screened cables to connect remote transmitters.
4. The face areas of the control part cover have to be before re-mounting clean, coated with a grease without any acid (e.g. vaseline) and sealing not damaged to avoid joint corrosion.
5. Reversation of the EA is sure, if the period between switching-off and switching-on of power supply for the reversed movement of the output part is minimally 50 ms.
6. Delay after switching-off, i.e. time since a reaction of switches till the motor is dead can be maximally 20 ms.
7. It is recommended to have the corresponding direction protection switched-off directly with the corresponding position or thrust switches.



Abide by instructions of valve producers, whether switching-off in limit positions is to be realised with position or thrust switches!

After electric connection perform checking of function:

- Put the valve manually to a mid-position.
- Connect the EA electrically for the chosen direction of movement and watch the output part movement.
- If it does not correspond change the order of feeding phases (valid for 3x400V version), or change leads of the feeding phase to the corresponding terminals (valid for 230V version).
- Check the control unit switches connection with switching consequently the contacts of the corresponding switches with pressing the control elements at running of the EA (at proper connection) to the chosen direction. In case of proper connection the EA stops or indicates the adjusted position according to switching of the chosen switch. If any of the functions is fault check connecting of the switches according to wiring diagrams.



In the **ST 1-Ex version** with the built-in **electronic controller** it is needed to perform **autocalibration** for assuring optimal functioning.

The procedure is as follows

Press the button **SW1** for about 2 sec (i.e. till the **D3** diode is got on) to set the controller to the **autocalibration** mode. During this process the controller checks the feedback transmitter and the sense of turning, puts the EA to the positions open and closed, measures inertia mass in the directions "opening" and "closing", and loads the adjusted parameters into the EEPROM memory. In case that during the initialisation process an error occurs (e.g. in connection or adjustment) the initialisation process will be interrupted and the controller with the **D4** diode reports about the type of the error. Else after finishing the initialisation process the controller is put into the **regulation mode**. If needed to change adjusted parameters of the controller follow instructions given in the part Adjusting of actuator.

3.3 Dismantling



**Before dismantling it is required to disconnect the EA from mains!
Do not connect and disconnect live connectors!**

- Disconnect the EA from mains.
- Disconnect the leads from the EA terminal boards and loosen the cables from bushings. Pull out the connectors in case of the connector version.
- Loosen the fixing screws of the EA flange and coupling screws and disconnect the EA from the valve.
- While sending the EA to be repaired put it into a package solid enough to avoid damages of the EA during transportation.

4. Adjusting of actuator



Abide by safety measures!

After mechanical connection, electrical connection and checking of connection and function start setting and adjustment of the device. The adjustment can be performed at a mechanically and electrically connected EA. This part describes adjustment of EA to specified parameters in case that any unit of EA is reset. Laying of adjusters of the control board is shown on Fig. 3

Following description is applicable to adjustment, when pull-rod by movement "opening" is going out and by movement "closing" is going inside the actuator.

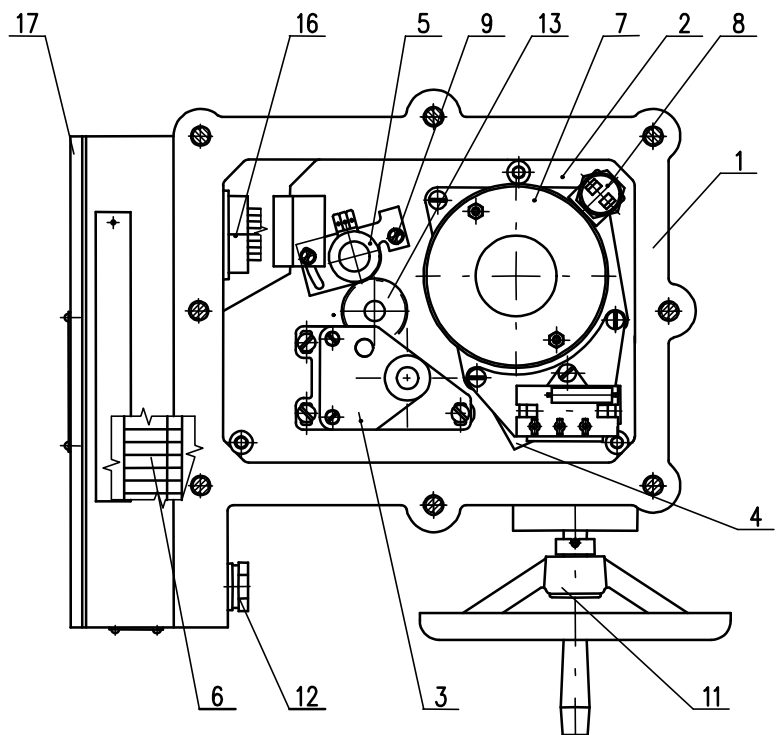

Fig.3

4.1 Gear unit adjustment

In the production plant switching-off thrust for both the "opening" direction (the thrust switch S1) as well as for the "closing" direction (the thrust switch S2) are adjusted to specified value $\pm 10\%$. If not agreed else they are adjusted to maximum value.

Adjustment and setting of the gear unit to other values without any testing device for thrust measuring is not possible.

4.2 Adjustment of position-indicating unit (Fig.4)

The EA are in the production plant adjusted to a fixed angle (according to the specification), given on the nameplate. While setting, adjusting and resetting follow these steps (Fig. 4):

- In potentiometer version disengage the transmitter.
- Loosen the nuts (23) fixing cams still having the Belleville spring creating axial pressure.
- Put the EA to the position "open" and turn the cam (29) counterclockwise until the switch S3 (25) switches.
- Change setting of the EA by the angle, where the position "open" is to be indicated and turn the cam (31) counterclockwise until the switch S5 (27) switches.
- Put the EA to the position "closed" and turn the cam (28) clockwise until the switch S4 (24) switches.
- Turn the EA back by the angle, where the position "closed" is to be indicated and turn the cam (30) clockwise until the switch S6 (26) switches.
- Having the EA adjusted lock the cams with the central milled nut and counter-nut (23).

If not agreed else the signalling cams are set next to the limit positions. The signal possibility is available along the whole operation angle in both directions, i.e. 100%.

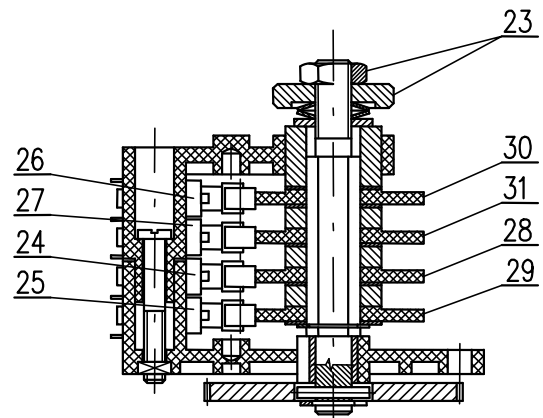

Fig.4

4.3 Adjustment of resistant transmitter (Fig. 5)

The **resistant transmitter** is in the EA **ST 1-Ex** used to function as a remote position indicator; in the EA **ST 1-Ex with controller** to function as a feedback in the position controller and if needed also in the position of a remote resistant position indicator. Before the resistant transmitter adjustment the position switches have to be adjusted. Adjustment consists in setting of the resistance in the defined limit position of the EA.

Notes:

In case that the EA is not used in the whole stroke range given on the nameplate, the resistance in the limit position "open" is proportionally reduced.

*In the EA **ST 1-Ex with controller** 2000W resistant transmitters are used. In the other cases if the resistant branch is lead to the terminal board the resistance of the transmitters is according to the customer's specification.*

To adjust the transmitter follow these steps:

- Loosen the fixing screws (9) of the transmitter holder and push the transmitter out of mesh.
- Connect a meter for resistance measuring to the terminals 71 and 73 of the EA **ST 1-Ex** terminal board, or to the terminals 6 and 7 of the EA **ST 1-Ex with controller** terminal board.
- Put the actuator to the position "closed" (with the hand wheel, or with the local electric position control until the corresponding position switch S2 or S4 switches).
- Rotate the transmitter shaft until resistance of $\leq 5\%$ of the nominal transmitter resistance can be read on the meter in case of EA **ST 1-Ex**, or 3 up to 5% of the nominal transmitter resistance in case of EA **ST 1-Ex with controller**, or in case of EA **ST 1-Ex with EPV**, i.e. with the resistant transmitter with the converter PTK1
- In the position put the transmitter to mesh with the drive wheel and fix the fixing screws on the transmitter holder.
- Disconnect the meter from the terminal board.

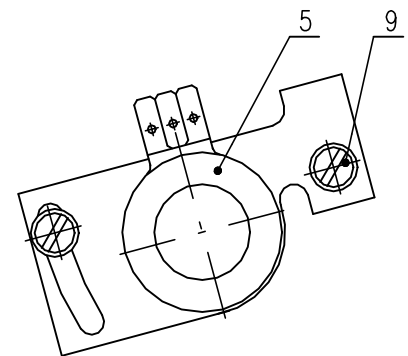

Fig.5

4.4 Adjustment of the Electronic Position Transmitter (EPV) - the Resistive Transmitter (Potentiometer) with the Converter PTK 1

4.4.1 EPV – the 2-wire version (Fig. 6)

The position transmitter with the converter PTK1 is in the plant adjusted to have the output current signal on the terminals 81-82 (the wiring diagram 74 0807 00) as follows:

- in the position „open“ 20 mA
- in the position „closed“ 4 mA

If the transmitter requires a new adjustment follow these steps:

Adjustment of the EPV in EA ST 1-Ex:

- Put the actuator to the position „closed“ and switch the power supply off.
- Adjust the resistive transmitter according to the previous chapter. The resistance is to be metered on the terminals X-Y (Fig. 6). The used transmitter resistance is 100 Ω.
- Switch the converter's power supply on.
- Turn the adjusting trimmer ZERO (Fig. 6) to adjust the output current signal rate measured on the terminals 81-82 to 4mA.
- Set the actuator to the position „open“.
- Turn the adjusting trimmer GAIN (Fig. 6) to adjust the output current signal rate measured on the terminals 81-82 to 20mA.
- Check the output signal of the converter in the both limit positions, and repeat the procedure if needed..

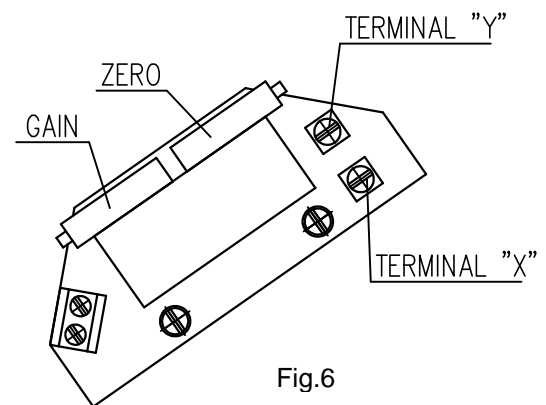

Fig.6

Note:

The output signal of 4-20mA can be adjusted at the range from 75 up to 100% of the rated stroke stated on the actuator's nameplate. At values less than 75% the value 20mA is reduced proportionally.

Adjustment of the EPV in EA ST 1-Ex with controller

- Disconnect the control signal from the terminals 86/87 and 88.
- Set the actuator to the direction "OPENING" or "CLOSING" with the hand wheel, or with connecting power to the terminals 1 and 20 for the direction "OPENING", or 1 and 24 for the direction "CLOSING".
- Set the actuator to the position "CLOSING" and switch the converter off on the terminals 1 a 61.
- Adjust the resistive transmitter according to the previous chapter. The resistance is to be metered on the terminals X-Y (Fig. 6).
- Connect power supply to the terminals 1 and 61.
- Turn the adjusting trimmer ZERO (Fig. 6) to adjust the output current signal rate measured on the terminals 81-82 to 4mA.
- Set the actuator to the position „open“.
- Turn the adjusting trimmer GAIN (Fig. 6) to adjust the output current signal rate measured on the terminals 81-82 to 20mA.
- Check the output signal of the converter in the both limit positions, and repeat the procedure if needed.
- Connect the control signal to the terminals 86/87 and 88.

4.4.2 EPV – 3-wire version (Fig. 7)

The resistive transmitter with the converter is in the plant adjusted to have the output current signal metered on the terminals 81-82 (the wiring diagram Z258 - without any power supply, or Z261 - with a power supply) as follows:

- in the position „open“ 20 mA or 5 mA
 - in the position „closed“ 0 mA or 4 mA
- according to the specified version of the converter.

If the transmitter requires a new adjustment follow these steps:

- Put the actuator to the position "closed" and switch the power supply off.
- Adjust the resistive transmitter according to the previous chapter. The resistance is to be metered on the terminals X-Y (Fig. 7). The used transmitter resistance is 2000Ω or 100 Ω.
- Switch the converter's power supply on.

- Turn the adjusting trimmer ZERO (Fig. 7) to adjust the output current signal rate measured on the terminals 81-82 to 0 mA or 4mA.
- Set the actuator to the position „open“.
- Turn the adjusting trimmer GAIN (Fig. 7) to adjust the output current signal rate measured on the terminals 81-82 to 20mA or 5 mA..
- Check the output signal of the converter in the both limit positions, and repeat the procedure if needed.

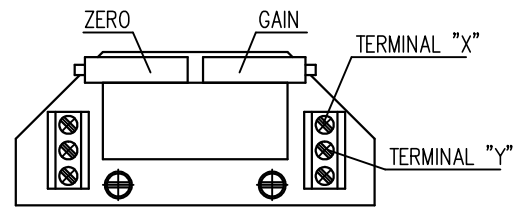

Fig.7

Note:

The output signal of (0-20mA, 4-20mA or 0-5mA - according to the specification) can be adjusted at the range from 85 up to 100% of the rated stroke stated on the actuator's nameplate. At values less than 85% the value of the output signal is reduced proportionally.

4.5 Adjustment of the Capacitive Transmitter CPT1/A (Fig.8)

The chapter describes adjustment of the capacitive transmitter to the specified parameters (standard values of output signals) in case they are reset. The capacitive transmitter serves as a position transmitter of electric actuators with unified output signal of 4÷20 mA in electric actuators **ST 1-Ex**, or as a feedback of a position controller, or if required it functions also as a remote position transmitter of electric actuators with unified output signal of 4÷20 mA in electric actuators **ST 1-Ex with controllers**.

Note:

In case that reversed output signals are needed (in the position "OPEN" minimum output signal) contact personnel of service centres.

The capacitive transmitter CPT1/A is adjusted by the producer to the fixed operation stroke according to the order and wired according to the wiring diagrams placed into the cover. Check the power supply of the user after connecting to terminal of the terminal board before the transmitter is electrically checked. Adjustment of the capacitive transmitter can be performed when the position switches are adjusted. The adjustment is performed with the power supply of 230 V/50 Hz and ambient temperature of 20±5°C.

The following versions of electric actuators with built capacitive transmitters can be specified :

- A) The version without any power supply** (2-wire version) for EA **ST 1-Ex**
- B) The version with a power supply** (2-wire version) for EA **ST 1-Ex**
- C) The version CPT as a feedback to the position controller** for EA **ST 1-Ex with controller**

A.) Adjustment of the Capacitive Transmitter without any Power Supply

Before connecting check the power supply. The measured voltage should be in range from 18 up to 28 V DC.



The voltage of the power supply must not be in any case higher than 30 V DC. The transmitter can be irreversibly damaged

While checking or adjusting the output signal of 4÷20 mA follow these steps:

- Connect a mA meter of precision class 0,5 and loading resistance lower than 500Ω serially with the transmitter (pole „-“; terminal 82)
- Put the actuator to the position "CLOSED", the signal value should decrease.
- Check the signal value for the position "CLOSED" (4 mA).
- Tune the signal with loosening the fixing screws (15) and turning the trimmer (10) until the required value of 4 mA is reached. Tighten the fixing screws.
- Put the actuator to the position "OPEN", the signal value should raise.
- Check the signal value for the position "OPEN" (20 mA).
- Tune the signal with turning the trimmer (20) until the required value of 20 mA is reached.
- Check the signal value for the position "CLOSED" and then for the position "OPEN".
- Repeat the procedure until the change from 4 to 20 mA is reached with deviation less than 0,5 %.
- Disconnect the meter and lock the screws with a varnish.

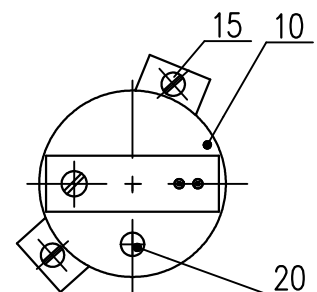

Fig.8

B.) Adjustment of the Capacitive Transmitter with the Power Supply:

- 1.) Check the power supply: 230 V AC $\pm 10\%$ on the terminals 78,79
- 2.) While checking or adjusting the output signal of 4÷20 mA follow these steps:
 - Connect a mA meter of precision class 0,5 and loading resistance lower than 500 Ω on the terminals 81,82.
 - Follow the procedure described in the previous chapter A.

C.) Adjustment of the Capacitive Transmitter Served as a Feedback of the Position Controller

While checking or adjusting the output signal of 4÷20 mA follow these steps:

- Disconnect the circuit on the terminals 81 and 82 removing the jumper.
- Connect power supply to the terminals 1 and 61.
- Disconnect the control signal from the terminals 86 and 88.
- Put the actuator to the direction "OPENING" or "CLOSING" with the hand wheel or connecting power supply to the terminals 1 and 200 for the direction "OPENING", or 1 and 24 for the direction "CLOSING".
- Connect a mA meter of precision class 0,5 (e.g. digital) and loading resistance lower than 500 Ω on the terminals 81,82.
- Follow the procedure for the version without any power supply described in the previous chapter A.
- Having the transmitter adjusted put the jumper again on the terminals 81 and 82 in case that the output signal wont be used (the circuit through the terminals 81 and 82 should be closed).
- Connect the control signal to the terminals 86 and 88.



The user has to arrange grounding of the 2-wire circuit of the capacitive transmitter to the electrical ground of a joined controller, computer, etc. The grounding should be performed only in one place in any part of the circuit outside the electric actuator!

Note:

The trimmer (20) can be used to adjust the output signal of the capacitive transmitter to any value of operation stroke in range from ca 40% up to 100% of the value of the operation stroke adjusted by the producer and stated on the actuator's nameplate.

4.6 Adjustment of position controller (Fig. 9)

The built-in position controller REGADA of new generation is a user-friendly control system to control actuators with an analogue signal. The controller takes advantages of high-power RISC processor MICROCHIP to perform all functions. It provides also continuous automotive diagnostics of the system, error messages as well as number of relay switching and number of controller's operation hours. Placing an analogue signal onto the input terminals of the terminal board 86/87 (GND, -) and 88 (+) causes that the EA output is reset.

Required parameters and functions can be programmed using function buttons SW1 - SW2 and LED diodes D3 - D4 placed directly on the controller, see Table 2.

4.6.1 Setting of controller

The controller's microprocessor unit is in the production plant programmed to parameters given in **Table 2** (Note 2).

Setting of the controller is performed using buttons and LED diodes.

Adjust the position and thrust switches and the position transmitter before adjustment of the controller.

Laying of adjusters and signalling elements on the board of the REGADA controller is shown on Fig.9:

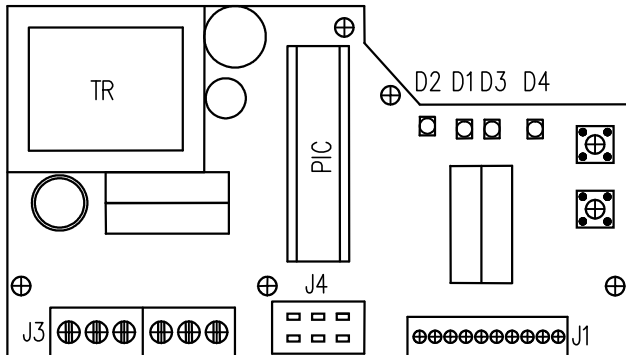

Fig. 9

SW1 button	starts an initialisation routine and allows listing in the adjust menus
SW2 button	setting of parameters in the chosen menu
D1 diode	power on indication
D2 diode	motion to the direction "opening" indication (green) - "closing" (red) indication
D3 diode	(yellow light) number of blinking codes indicates chosen adjust menu
D4 diode	(red light) number of blinking codes indicates adjusted parameter of the controller from the chosen menu

Table 2

D3 (yellow) diode number of blinking	Adjust menu	D4 (red) diode number of blinking	Adjusted parameter
1 blink	control signal	1 blink	0-20mA
		2 blinks	4-20 mA (*) (**)
		3 blinks	0-10V DC
2 blinks	response for signal SYS-TEST	1 blink	EA opens receiving signal SYS
		2 blinks	EA closes receiving signal SYS
		3 blinks	EA stops receiving signal SYS (*)
3 blinks	mirroring (ascending/descending characteristics)	1 blink	EA CLOSING at increasing of control signal
		2 blinks	EA OPENING at increasing of control signal (*)
4 blinks	insensitiveness of controller	1 to 10 blinks	insensitiveness of controller of 1-10% (3% set by the producer) (*)
5 blinks	way of regulation	1 blink	narrow thrust
		2 blinks	narrow position (*)
		3 blinks	wide thrust
		4 blinks	wide position

Notes:

1. The controller at autocalibration automatically sets the feedback type - resistant/current
2. (*) Parameters set in the production plant, if customer has not stated else.
3. (**) Input signal
4 mA - position "closed"
20 mA - position "open"

Standard setting of controller (programmed RESET of controller) - in case of any problems with setting of the parameters it is possible with pressing both **SW1** and **SW2** at the same time and then switching power on to set the standard parameters.

Controller setting procedure:

- Set the actuator into a mid-position.

The initialisation routine starts at the switched-on controller, zero system deviation and short pressing of the SW1 button for ca 2 sec (i.e. until the diode D3 got on). Loosing the button some of the default menus starts (usually control signal) what is shown with 1 blink on the D3 diode as well as one of the default parameters (usually control signal of 4-20mA) what is shown with 1 blink on the D4 diode. Then the required parameters of the controller can be changed according to Table 2:

- press shortly the SW1 button to list the menu shown with the blinking number on the D4 diode.
- press shortly the SW2 button to set parameters shown with the blinking number on the D4 diode.

After changing of the parameters according to user's wishes, put the controller to autocalibration with pressing the SW1 button for ca 2 sec (i.e. until the diode D3 got on). During this process the controller performs the feedback transmitter and turning sense checking, sets actuator to the positions "open" and "closed",

measures inertia mass in the directions "opening" and "closing", and loads the adjusted parameters into the EEPROM memory. In case that during the initialisation process an error occurs (e.g. in connection or adjustment) the initialisation process will be interrupted and the controller with the D4 diode reports about the type of the error. Else after finishing the initialisation process the controller is put into the regulation mode.

Error messages of the controller with D4 diode at initialisation:

- 4 blinks.....improper connection of the thrust switches
- 5 blinks.....improper connection of the feedback transmitter
- 8 blinks.....bad sense of actuator's turning direction or adverse connection of the feedback transmitter

4.6.2 Watching operation and error states

Watching operation and error states is possible with the EA open.

a.) Operation status with the D3 LED diode indicating:

- it is continuously lighting - the controller regulates
- it is continuously not lighting - system deviation in the insensitiveness range - the EA has stopped

b.) Error state with the D4 and D3 LED diodes indicating - D4 continuously lighting, D3 indicates error state with blinking

1 blink (repeated):	- indication of the "TEST" mode - the EA is put to the position according to the signal in the "TEST" menu (at connecting the 66 and 86/87 terminals)
2 blinks (repeating after short pause):	- missing of control signal - the EA is put to the position according to the signal in the "TEST" menu
4 blinks (repeating after short pause):	- thrust switches activity indication (the EA switched-off with the thrust switches in a mid-position)
5 blinks (repeating after short pause):	- failure of the feedback transmitter - the EA is put to the position according to the signal in the "TEST" menu
7 blinks (repeating after short pause):	- control signal (current at range 4-20mA less than 4mA (3.5mA))

5. Service, maintenance and troubleshooting

5.1 Service



1. In general it is provided that service of the EA is performed by a qualified worker in accordance with requirement given in Chapter 1!
2. After putting the EA into operation it is needed to verify whether during manipulation any scratch on surface occurred, it is to be removed to prevent actuator against corrosion!

The EA ST 1-Ex or ST 1-Ex with controller requires just negligible service. Proper putting into operation is a recondition of reliable operation.

The service of the EA leads from the operation conditions and usually resides in information processing for further arranging of required functions.

The stuff has to perform prescribed maintenance to prevent the EA during operation against impacts of environment, which exceed the frame of allowed influences.

Manual control:

If needed (during adjusting, function checking, failure etc.) the stuff can change setting of the controlled body using the hand wheel. While rotating the hand wheel counterclockwisely the output part moves in the direction "Z - closed".

5.2 Maintenance - extent and periodicity

All screws and nuts affecting tightness and protection (IP) must be tighten during the inspection and maintenance. Similarly, once a year should be checked and if necessary tighten mounting screws of the terminal wires and assuring of the slip-on joints with wires.

The internal between two preventive inspections is four years.

In case of damage or after 6 years of the actuator's operation the replacement of cover seals and oil filling seals must be done.

The grease in the supplied actuators is designed for the lifetime of the product. It is not necessary to change the grease during the operation of the actuator.

Lubrication:

- - gear part - in versions for climate with temperatures -25°C till +55°C – grease HF 401/0 (GLEIT- μ) resp. GLEITMO 585 K
- - in versions for climate with temperatures -50°C till +40°C grease ISOFLEX TOPAS AK 50.
- - linear adapter – grease GLEIT- μ - HP 520M (to -25°C) resp. HP 520S (to -40°C).



Lubrication of the valve stem is independent on maintenance of the EA!

After every potential flooding of the product check, whether there is no water inside. After eventual water penetration, dry the product before repeated putting into operation and replace damaged sealings, resp. other parts of EA. identically check also tightness of cable bushings and replace them, if they are damaged.

- Every six months it is recommended to perform one check move in frame of adjusted operation stroke to verify reliability of functioning with setting back to the original position.
- If the audit rules do not determine else the inspection of EA is performed ones a year and tightening of all connecting and grounded screws have to be checked to avoid overheating.
- After 6 months from putting of EA into operation and once a year it is recommended to check tightening of fixing screws between the EA and the valve. (Tighten the screws with the cross system.)
 - While connecting and disconnecting of the EA check the tightness of cable glands – those with damaged sealings should be replaced by new ones of the approved type!
 - Keep the EA clean and take care about removing impurities and dust. The cleaning has to be performed regularly according to the operation possibilities and requirements.



5.3 Maintenance to assure inexplosiveness

A half an hour before removing of the actuator cover it is needed to switch power supply off. The given period is required to assure cooling of the electric motor and the space heater below the admissible temperature value of the temperature class T6 (85 °C).

The fixing screws of the upper cover have to be always in full numbers, i.e. 8 pcs, with flexible washers and tightly fastened.

The actuators with damaged closing surfaces, e.g. scratches, rifts, etc. have to be immediately put out of operation.

The closing surfaces are (Fig.10):

- the connecting surface of the upper cover and the lower case (1),
- the cylinder part of the manual control mechanism flange and shaft (2),
- the cylinder part of the lower case and the cylinder part of the manual control mechanism flange (3),
- the cylinder part of the lower case and the cylinder part of the crown wheel flange (4).
- the cylinder part of the crown wheel and of the indication shaft (5)

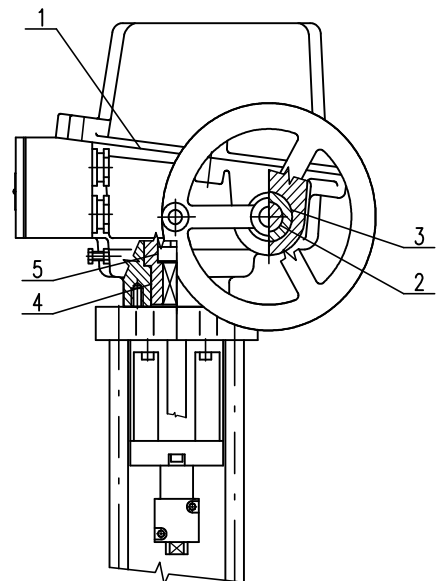

Fig. 10

5.4 Troubleshooting

At failure of power supply the EA stops in the position where it was before the failure. If needed the EA can be set only with the manual control (the hand wheel). After restoration of power the EA is prepared for operation.

In case of failure of any element of the EA it can be changed by a new one. Entrust the change to a service centre.

In case of an EA failure, which cannot be eliminated directly in operation, follow instructions for under-guaranty and after-guaranty service.

For controller repair a F1,6 A subminiature fuse for PCB should be used, alternatively also F 2A, 250 V e.g. Siba type 164 050.1,6 or MSF 250, and for DB voltage source repair a M160 mA, 250V fuse, e.g. Siba, or MSF 250.

Note: If the EA requires dismantling follow the chapter "Dismantling".



Taking the EA to pieces for repair purposes is allowed only by professionally qualified persons trained in the production plant or by a contracted service centre!

6. Accessories

The EA is delivered with the hand wheel.

7. Enclosures

7.1 Wiring diagrams

Wiring diagrams EA ST 1-Ex

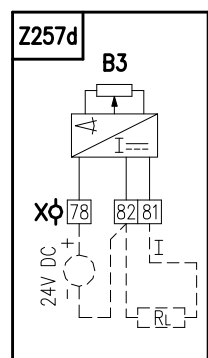
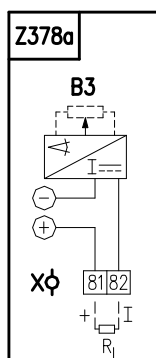
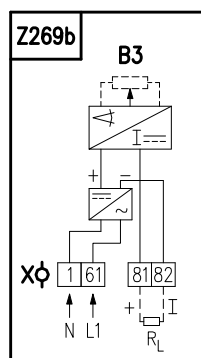
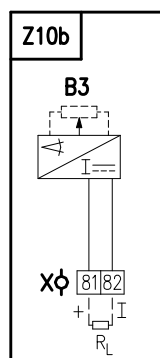
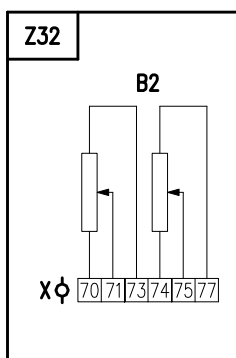
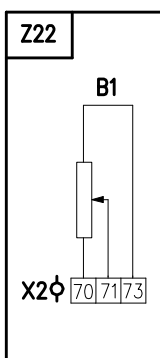
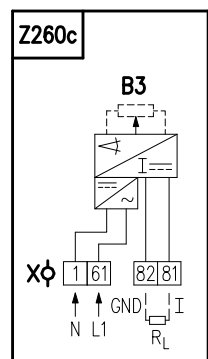
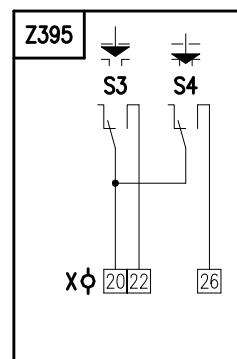
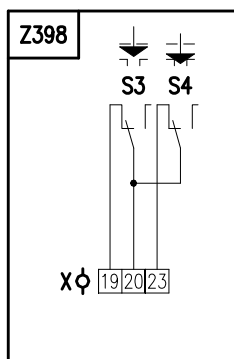
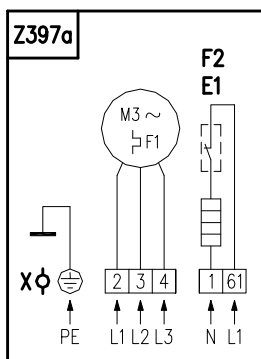
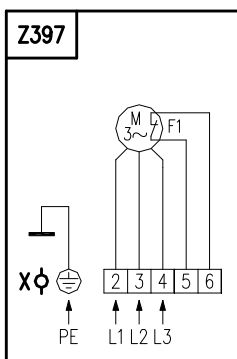
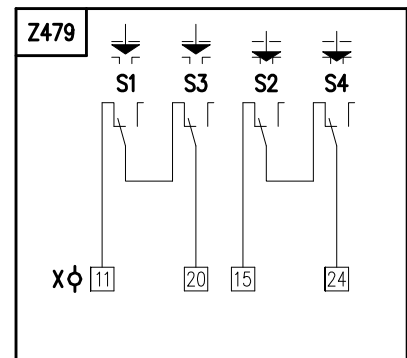
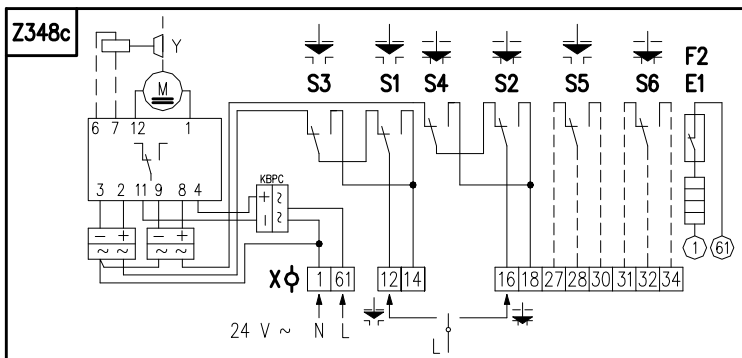
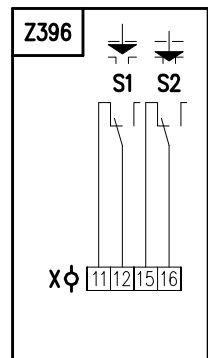
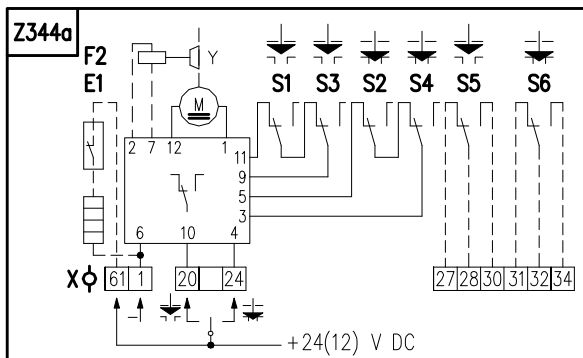
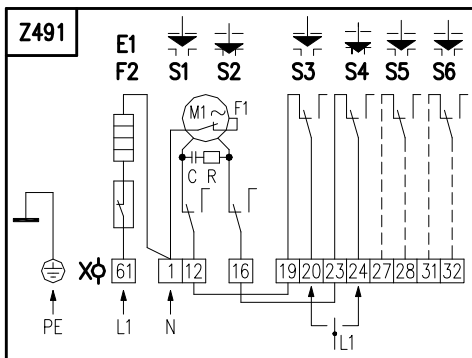

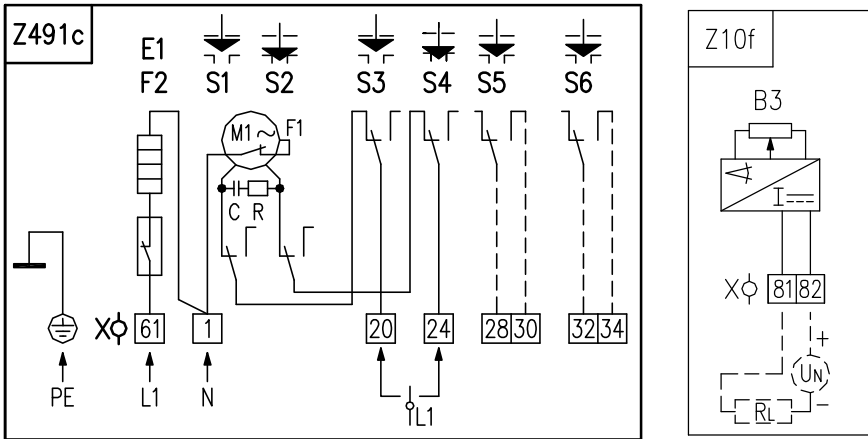

Wiring diagrams EA ST 1-Ex with controller

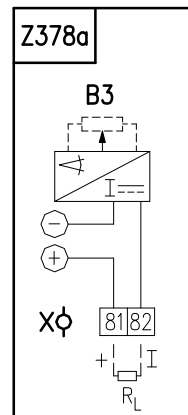
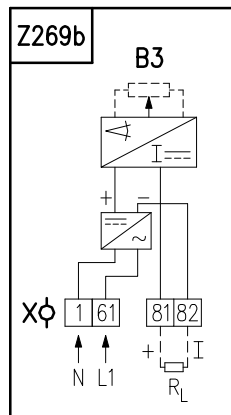
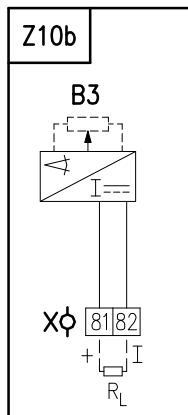
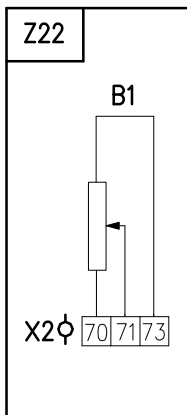
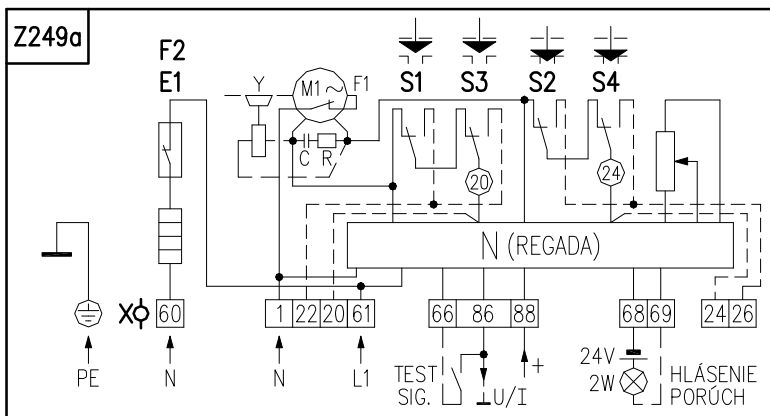
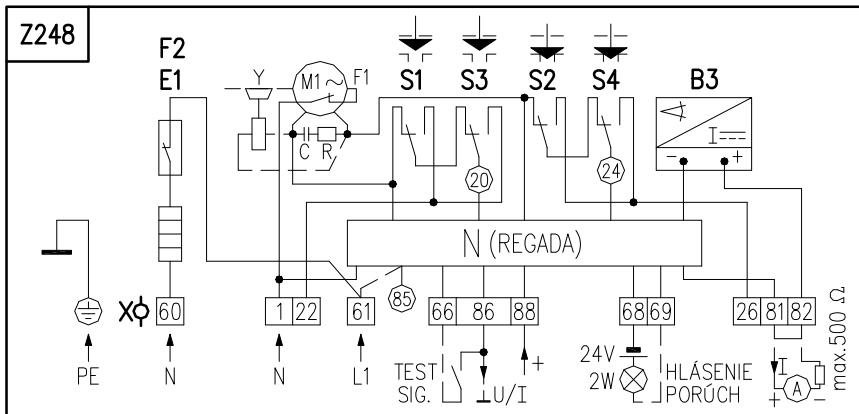

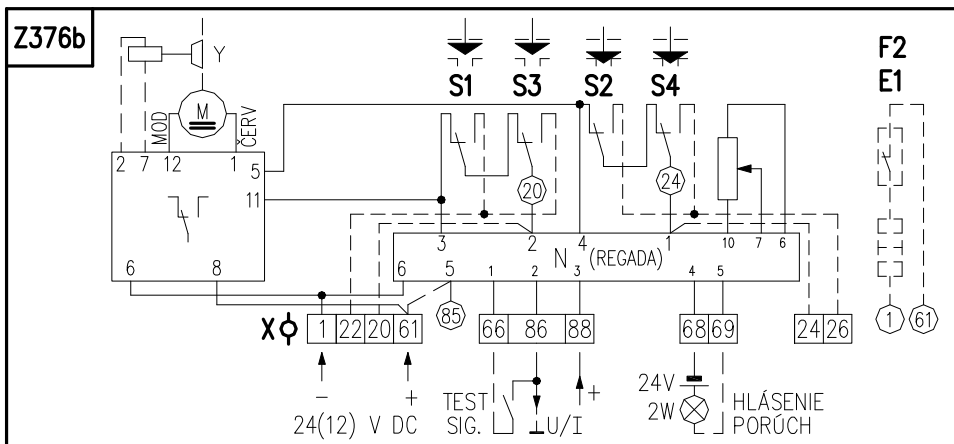
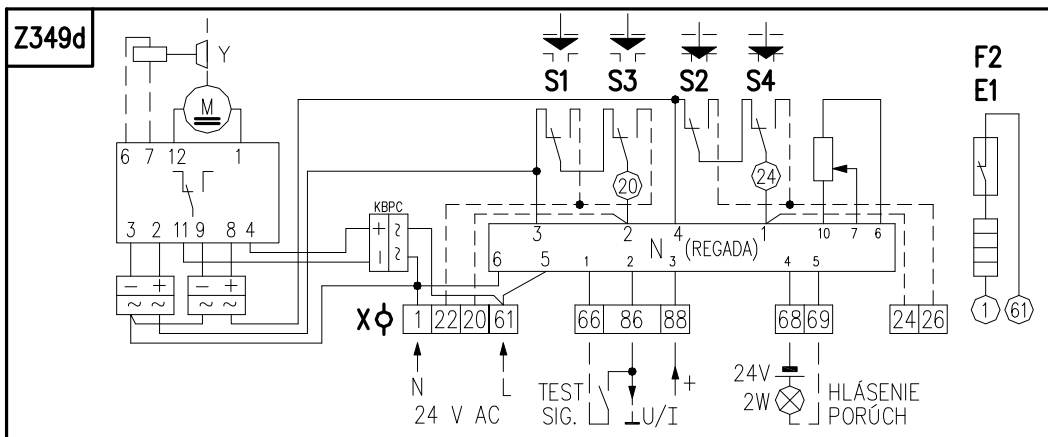
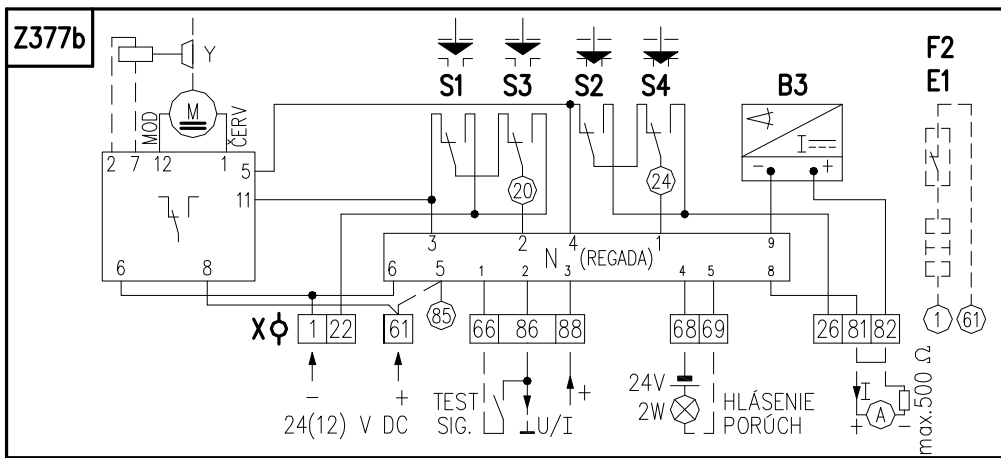
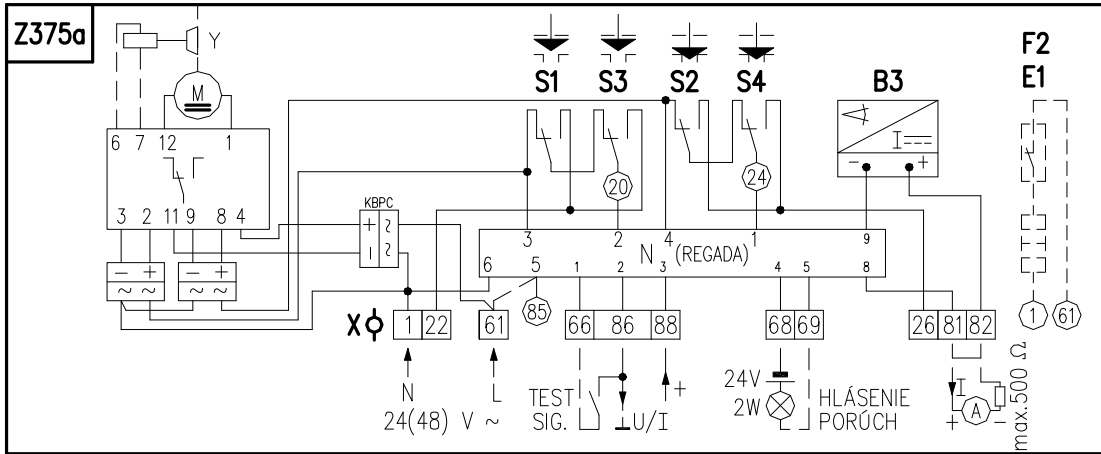

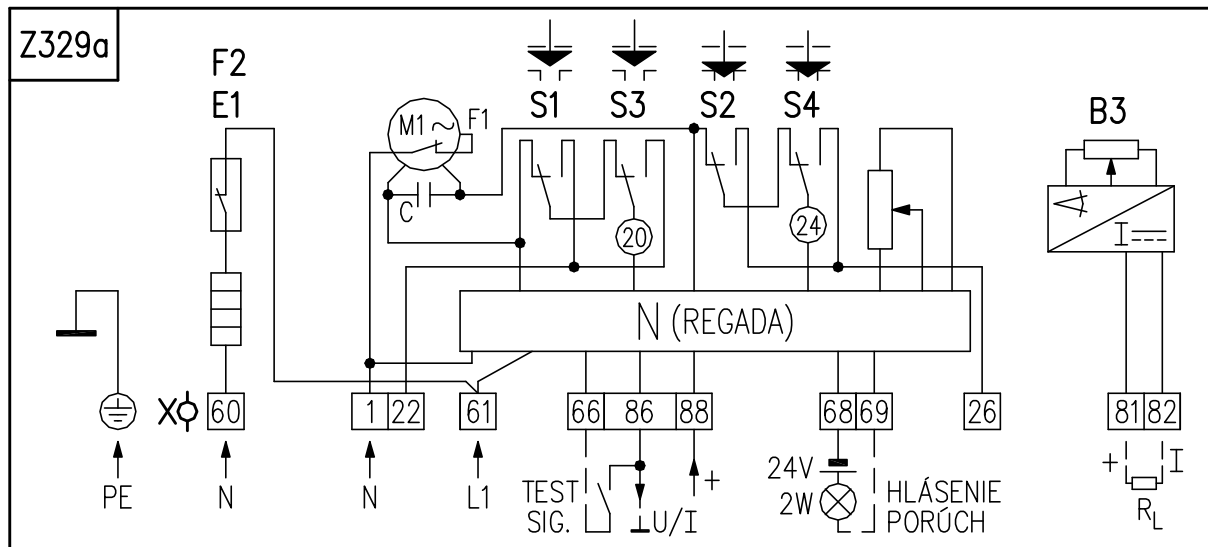
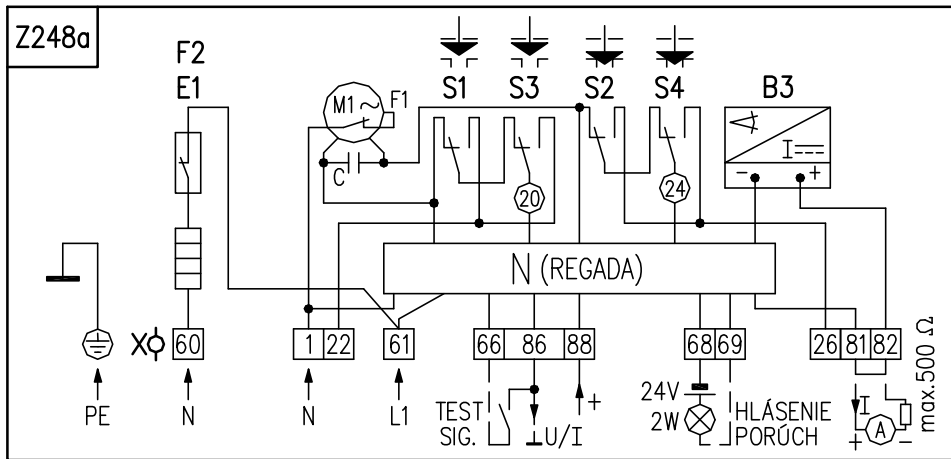

Legend:

- Z10b, Z10f ..wiring diagram of resistive with current converter or capacitive transmitter – 2 - wire without supply
- Z22.....wiring diagram of single resistant transmitter connection
- Z32.....wiring diagram of double resistant transmitter
- Z248, Z248a.... wiring diagram of EA ST 1-Ex with controller with current feedback - 230 V AC
- Z249a.....wiring diagram of EA ST 1-Ex with controller with resistant feedback - 230 V AC
- Z329a.....wiring diagram of EA ST 1-Ex with controller with resistant feedback - 2-wire version with power supply - 230 V AC
- Z257d.....3-wire version of EPV - without power supply connection
- Z260c.....wiring diagram of resistive transmitter with current converter -3-wire version with power supply
- Z269b.....wiring diagram of resistive transmitter with current converter or capacitive transmitter -2-wire version with power supply
- Z344a.....wiring diagram of electric motor 24 V DC
- Z348c.....wiring diagram of EA with electric motor 24 V AC
- Z349d.....wiring diagram of ST1- Ex with controller and resistant feedback for electric motor – for 24 V AC
- Z375a.....wiring diagram of ST1- Ex with controller and current feedback for electric motor – for 24 V AC
- Z376b.....wiring diagram of ST1- Ex with controller and resistant feedback for electric motor – for 24 V DC
- Z377b.....wiring diagram of ST1- Ex with controller and current feedback for electric motor – for 24 V DC
- Z378a.....wiring diagram of resistive with current converter or capacitive transmitter 2 and 3 - wire with supply
- Z395.....wiring diagram of additional position switches for 3-phase electric motor
- Z396.....wiring diagram of additional position switches for 3-phase electric motor
- Z397.....wiring diagram of 3-phase electric motor with terminated thermal protection
- Z397a.....wiring diagram of 3-phase electric motor with terminated thermal protection
- Z398.....wiring diagram of switches S1, S2 – for 3-phase electric motor
- Z491, Z491c... wiring diagram of EA with electric motor 230 V AC

- | | | | |
|----------|--------------------------------|----------|-----------------------------------|
| B1 | single resistant transmitter | E1 | space heater |
| B2..... | double resistant transmitter | F1 | electric motor thermal protection |
| B3..... | capacitive transmitter, or EPV | F2 | space heater thermal switch |

I/U	input (output) current (voltage) signals	S2	thrust switch "closed"
M	single-phase electric motor	S3	position switch "open"
C	capacitor	S4	position switch "closed"
N	position controller	S5	additional position switch "open"
R	voltage-dropping resistor (for 230V only)	S6	additional position switch "closed"
R _L	voltage-dropping resistor	X	terminal board
S1	thrust switch "open"	Y.....	brake of electric motor

1. In case, that output signal from the capacitive transmitter (wiring diagram Z248,Z248a,377b,Z375a) is not used (incomplete circuit between terminal 81 and 82), it is required to connect clamps 81 and 82 by jumper (jumper is connected at manufacturing plant for connecting to terminal board only). By using output current signal from capacitive transmitter it is needed to remove jumper.

2. In the version equipped with the controller device while using the feedback from transducer CPT; when using the output signal there has been no galvanic isolation of the signal from the input one!

3. In case that galvanically separated output signal is needed it is necessary to use galvanical separation element (is not part of delivery), e.g. NMLSG.U07/B (producer SAMO Automation s.r.o.). After discussion this module could be supplied by EA producer.

7.2 Dimensional drawings

Flange ISO 5210

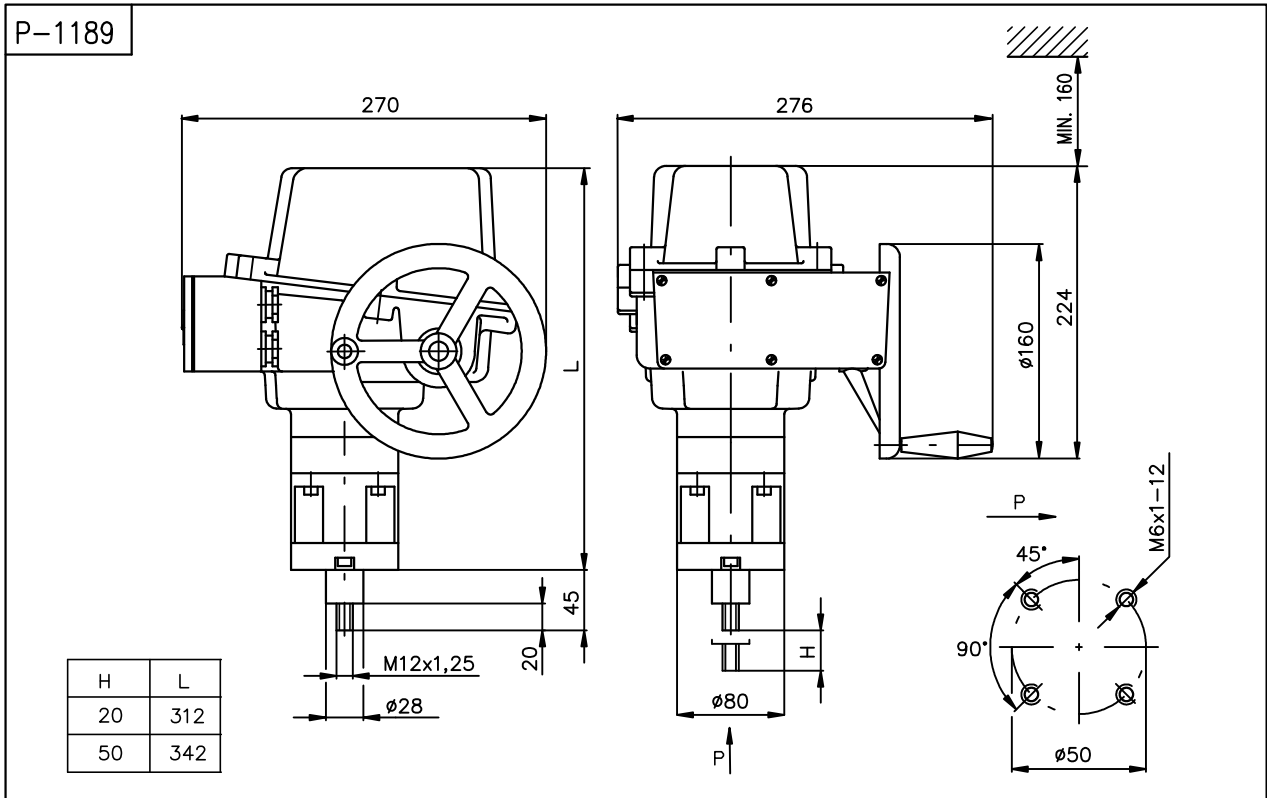

Pillars

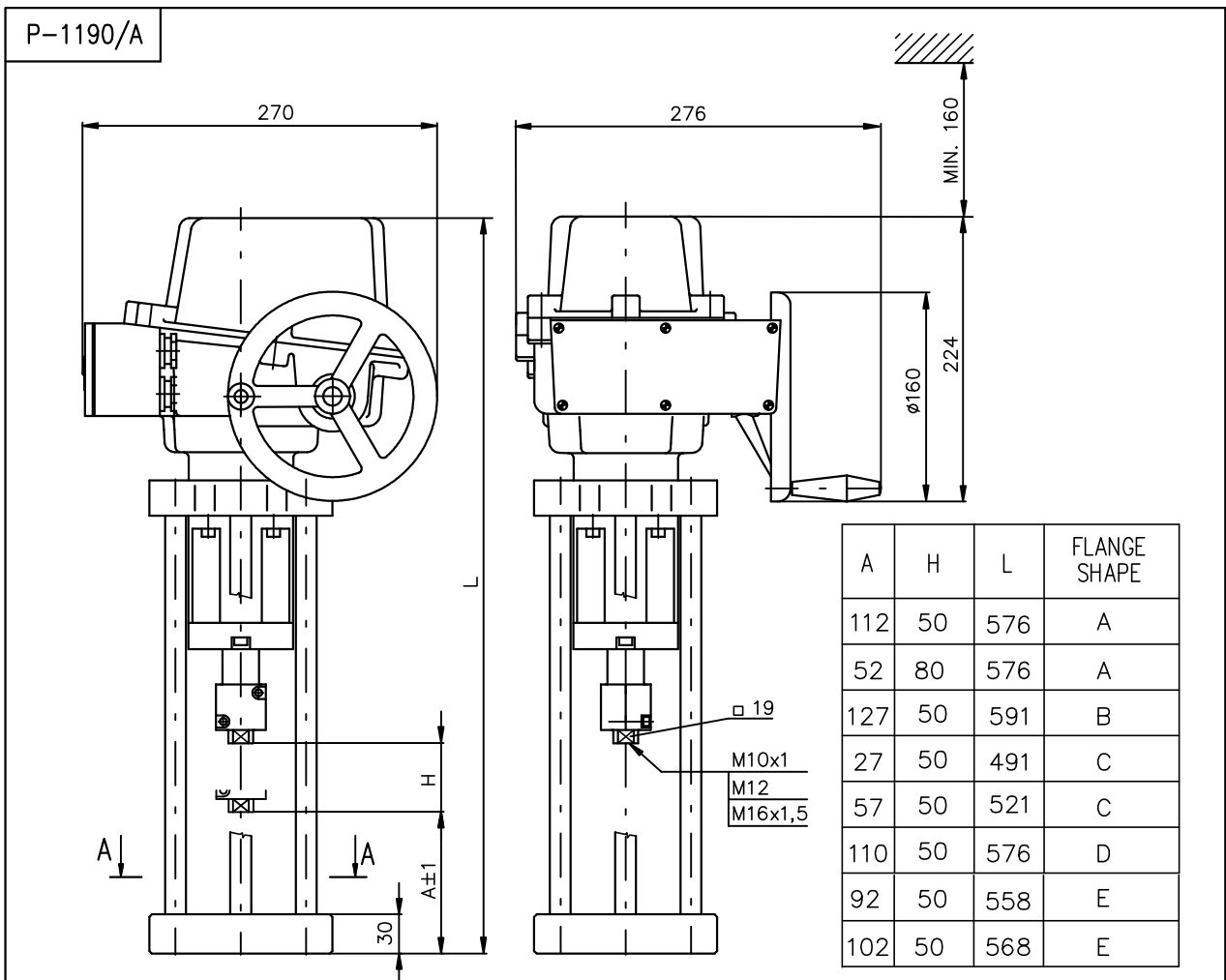

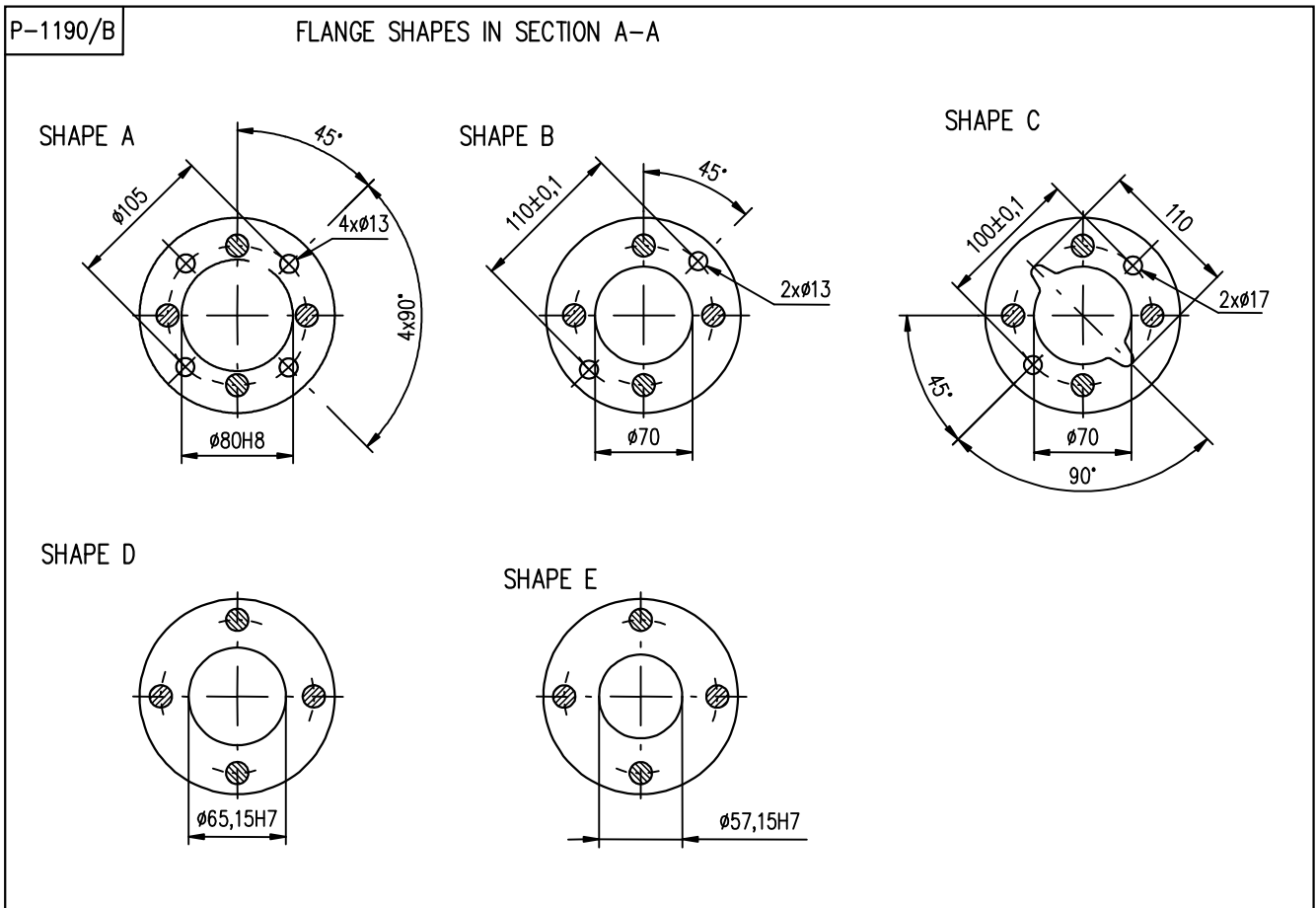

7.3 List of contractual after-sales service centres

Regada, s.r.o.
 Strojnícka 7
 080 01 Prešov
 Slovak Republic

Tel.: +421 51 7480 460
 Fax: +421 517732 096
 E-mail: regada@regada.sk
www.regada.sk